



## **HAMBURG CITY COUNCIL AGENDA** **AUGUST 16, 2022**

1. **Call City Council Meeting to Order**
  - **Pledge of Allegiance**
  
2. **Public Comment** *(Individuals may address the City Council about any non-agenda item(s) of concern. Speakers must state their name, address, and limit their remarks to three minutes. The City Council may not take official action on these items and may refer the matter to staff for a future report or direct that the matter be scheduled for a future meeting agenda.)*
  
3. **Agenda Review (Added Items) and Adoption**
  
4. **Consent Agenda** *(NOTICE TO PUBLIC: All those items listed as part of the Consent Agenda will be approved by a single motion, unless a request to discuss one of those items is made prior to that time. Anyone present at the meeting may request an item to be removed from the consent agenda. Please inform the Council when they approve the agenda for this meeting.)*
  - **Approve Added Claims for June 2022 (-\$1,352.47)**
  - **Approve Added Claims for July 2022 (\$6,365.15)**
  - **Approve August 2022 Claims (\$44,282.83)**
  - **Approve Temporary On-Sale Liquor License for Hamburg Lions Club**
    - **September 10, 2022**
  - **Approve Time-Off Request for Brandon Bracht**
  - **Approve Tim-Off Request for Jeremy Gruenhagen**
  - **Utility Bills Delinquency Report for July 2022**
  - **MRWA Serv Line Leak Protection Program**
  
5. **Hamburg Fire Department – Chief Siewert**
  - **Pension Raise/Officer Raises**
  - **Upcoming Officer Selection**
  
6. **Brandon Bracht (Public Works)**
  - **First 100 Days**
  - **New City Truck**
  - **Rekey City Buildings**
  - **Sell Old City Generator**
  - **Bobcat Toolcat Repairs**
  - **New Pressure Washer for City Shop**
  - **Dell Computer Quote (Laptop for City Shop)**
  
7. **Mike Royal (420 Henrietta Avenue)**
  - **Solar Panel Project (Wolf River Electric)**



***HAMBURG CITY COUNCIL AGENDA  
AUGUST 16, 2022***

**8. Old City Business**

- **Baseball Park Repairs Update**
- **Update City Liquor License Ordinance**
  - **Allow Sale of Strong Beer/Wine for Baseball Club**
  - **Allow the Sale of Alcohol within Public ROW/Street for Parkside Tavern Events**
- **Public Sale of Tax Forfeited Lot / Easements**
  - **Hamburg Zoning Code (Combining Parcels That Don't Share a Property Line)**
- **PT Help for Public Works**
- **Public Nuisance Violations**

**9. New City Business**

- **CarverLink Fiber Diversity Route**
- **Security Bank Safety Deposit Box Lease**
- **Sewer/Water Utility Trace Wire Specifications**

**10. City Council Reports**

- **Councilmember Jason Buckentin (Streets)**
- **Councilmember Eric Poppler (Parks)**
- **Councilmember Jessica Weber (Buildings)**
- **Councilmember Tim Tracy (Water/Sewer)**
- **Mayor Chris Lund**

**11. Adjourn City Council Meeting**



***HAMBURG CITY COUNCIL AGENDA  
AUGUST 16, 2022***

**PARK ACTIVITIES**

<b>AUGUST</b>	<b>15 – Hamburg Lions</b>
<b>SEPTEMBER</b>	<b>24 – Big Rib Jig / Kick Ball (?)</b>

**COMMUNITY HALL**

<b>AUGUST</b>	<b>27 – Wedding Reception</b>
<b>SEPTEMBER</b>	<b>10 – Wedding Reception</b>

**COMMUNITY CENTER (FIRE HALL) ACTIVITIES**

<b>AUGUST</b>	<b>16 – Hamburg City Council Meeting – Young America Township Meeting 21 – Community Center Rental 27 – Community Center Rental 29 – Hamburg Fire Dept. (Relief Association) Meeting</b>
<b>SEPTEMBER</b>	<b>6 – Mayor’s In Time 13 – Hamburg City Council Meeting 13 – Young America Township Meeting 15 – Farm Land Auction 19 – Hamburg Lions 26 – Hamburg Fire Dept. (Relief Association) Meeting</b>

**2022 June Claims List**

CHECK #	VENDOR	FUND	CLAIM DESCRIPTION	AMOUNT	APPROVED	
ACH	EFTPS	Divided	Fed, Social Security, MC - May 2022	\$3,961.52	6/14/2022	
ACH	MN Dept. of Revenue	Divided	State Withholding Tax Payment - May 2022	\$723.00	6/14/2022	
ACH	PERA	Divided	PERA Withholding - May 2022	\$811.25	6/14/2022	
ACH	PERA	Divided	PERA Withholding - June 2022	\$692.37	6/14/2022	
ACH	PERA	Divided	PERA Withholding - June 2022	\$505.03	7/26/2022	
ACH	HealthPartners	Divided	Health Insurance for June 2022	\$6,311.64	6/14/2022	
ACH	Greg Schultz	Divided	Wages 5-16-22 to 5-29-22	\$955.40	6/14/2022	
ACH	Brandon Bracht	Divided	Wages 5-16-22 to 5-29-22	\$1,754.05	6/14/2022	
ACH	Tamara Bracht	Divided	Wages 5-16-22 to 5-29-22	\$958.24	6/14/2022	
ACH	Jeremy Gruenhagen	Divided	June Wages (Rounds)	\$2,172.71	6/14/2022	
ACH	Greg Schultz	Divided	Payout of Sick/Vacation Time	\$4,885.15	7/26/2022	
ACH	Brandon Bracht	Divided	Wages 5-30-22 to 6-12-22	\$1,768.07	7/26/2022	
ACH	Tamara Bracht	Divided	Wages 5-30-22 to 6-12-22	\$985.86	7/26/2022	
ACH	Google	General Gov't	Email Accounts (14) Administered by Google G Suite	\$168.00	6/14/2022	\$13,479.48
ACH	Security Bank & Trust	General Gov't	ACH Service Fees for May 2022	\$35.90	6/14/2022	
ACH	Verizon Wireless	General Gov't	City Cell Phone Plan	\$129.05	6/14/2022	
ACH	ZOOM	General Gov't	Video Conferencing	\$16.09	6/14/2022	
ACH	Kwik Trip	Divided	Fuel for City Vehicles and FD	\$244.35	6/14/2022	
Debit Card	Amazon	Divided	Rain Gauge, Cleaning Supplies, Office Supplies (Paper)	\$176.96	6/14/2022	
Debit Card	Amazon	General Gov't	Ink Cartridges fro Shop Printer	\$85.50	6/14/2022	
Debit Card	Mid-County Coop	Divided	Weed Killer Chemicals	\$299.06	6/14/2022	
Debit Card	Amazon	Sewer	Dawn Dish Soap	\$16.62	7/26/2022	
Debit Card	Amazon	Sewer	Dawn Dish Soap	\$16.62	7/26/2022	
Debit Card	Amazon	Park & Rec.	Hearing Protection Headphones	\$84.99	7/26/2022	
Debit Card	Amazon	General Gov't Bldgs	2 Scan Disc Memory Cards	\$16.59	7/26/2022	
Debit Card	USPS	General Gov't	EDDM Postage for June 17, 2022 Newsletter	\$79.40	7/26/2022	
Debit Card	MN Rural Water Association	Public Works	Hydrant Repair Training	\$150.00	7/26/2022	
21116	212 Equipment	General Gov't	Weed Whip and Power Head	\$805.60	6/14/2022	
21117	Abdo	General Gov't	Certified Audit Services per Agreement for Year-ended 12-31-2021	\$4,000.00	6/14/2022	
21118	Bolton & Menk	General Gov't	Profes. Services for Research & Corresp. for Signage,Storage Buildings, .	\$320.00	6/14/2022	
21119	Bradley Security	Water	Remove Exit Device, Tighten Cylinders and Test at WTP	\$196.00	6/14/2022	
21120	CarverLink	Divided	Internet Services - May	\$80.00	6/14/2022	
21121	Carver County Sheriff	Public Safety	2022 Police Contract - 1st Half	\$8,631.50	6/14/2022	
21122	Cintas	Hall	Cleaning Supplies	\$101.71	6/14/2022	
21123	Clarke Mosquito Management	Public Safety	Mosquito Control 2022 (First of 3 Treatments)	\$1,364.75	6/14/2022	
21124	Coordinated Business Systems	General Gov't	Intermedia Monthly Charge Services and Equipment	\$57.16	6/14/2022	
21125	Dammann Seed Sales	Hall	5 Bags of 25# Athletic Turf Mixture for Behind the Hall	\$475.00	6/14/2022	
21126	Flow Measurement & Conrol	Divided	Certification of Wet Well, Pump #2 and Well #3	\$848.00	6/14/2022	
21127	Gopher State One	Divided	May Locates (15)	\$20.25	6/14/2022	
21128	Home Solutions	Divided	GT Adjustable Nozzle, Rodent Bait, and Trap	\$32.37	6/14/2022	
21129	Jaime Haas	Park	Refund of Park Rental Damage Deposit	\$100.00	6/14/2022	
21130	Loffler Companies	General Gov't	May Copies	\$78.14	6/14/2022	
21131	McLeod Publishing	General Gov't	Job Posting Advertisement for Part-time Summer Help	\$69.60	6/14/2022	
21132	Minnesota Pump Works	Sewer	Pulled Pump #2 at Park, Cleared of RV Hose, Reinstalled & Tested	\$771.40	6/14/2022	
21133	MN Department of Health	Water	2nd Quarter 2022 Community Water Supply Service Connect Fee	\$524.00	6/14/2022	
21134	MNSPECT, LLC	Public Safety	Residential Building Permits @ 821 William, 150 Jacob, 625 Kim	\$304.28	6/14/2022	
21135	MVTL Labs	Sewer	Sewer Pond Sample on 5-25-22/5-30-22/6-9-22	\$312.00	6/14/2022	
21136	NAPA Auto Parts	General Gov't Bldgs	1 Case Heavy Duty Oil, 1 Quart 2 Cycle MP Lube	\$55.37	6/14/2022	
21137	North American Safety	Public Works	5 Embroidered Safety Shirts	\$294.50	6/14/2022	
21138	Plunkett's Pest Control	General Gov't Bldgs	General Pest Control at City Hall and FD on 6-3-2022	\$42.13	6/14/2022	
21139	S.E.H.	Divided	2022 Street Project, Water Tower Demo, Sewer Lift and Pond Inquiry	\$1,223.57	6/14/2022	
21140	Viking Bottling Company	Divided	Syrup Canisters for Hall, Bottled Pop for Park Machine	\$534.50	6/14/2022	
21141	W.W.O.T.A	Divided	Water/Wastewater Training & Assistance for May 2022	\$875.64	6/14/2022	
21142	Waste Management	Sanitation	30 Yard Flat Waste Container for May	\$296.04	6/14/2022	
21143	Wm. Mueller & Sons	Divided	Fuel for City Vehicles and Equipment	\$625.54	6/14/2022	
21144	Xcel Energy	Divided	Electricity/Natural Gas Services	\$2,444.91	6/14/2022	
21145	VOID	VOID	VOID - Printer Issue	\$0.00	7/26/2022	
21146	VOID	VOID	VOID - Printer Issue	\$0.00	7/26/2022	
21147	212 Equipment	Divided	High-Flo Demand Pump, Mower Blade and Grease for Exmark	\$330.16	7/26/2022	
21148	Abdo	General Gov't	Review of the Office of State Auditor City Financial Reporting Form	\$825.00	7/26/2022	
21150	Canon	General Gov't	Canon Copier Gov't Contract for June	\$33.13	7/26/2022	
21151	Countryside Flagpole	General Gov't	Solid Brass Flag Snap, Bucket Truck Service	\$257.50	7/26/2022	
21152	Ehlers Bond Trust Services	Public Works (Streets)	General Obligation Improvement Bond, Series 2007A	\$333.75	7/26/2022	
21153	Galls	Public Safety (FD)	Uniforms	\$732.53	8/16/2022	
21154	Gopher State One	Divided	5 March Locates	\$6.75	8/16/2022	
21155	Hawkins Chemicals	Water	Chemicals for WTP	\$1,006.15	8/16/2022	
21156	Home Solutions	Divided	Bow Rake, Sprinkler, 2 Way Connector, Hamm Bit, Misc. Hardware, 4" Fra	\$113.39	8/16/2022	
21157	Jared Mackenthun	Public Safety (FD)	Mileage Reimbursement for State School and FAO Classes	\$198.31	8/16/2022	
21158	Melchert-Hubert & Sjodin PLLP	General Gov't	Data Practices Act, Liquor License, Employment, Storm Sewer/Old RR	\$2,784.60	8/16/2022	
21159	Metronet	Divided	Fiber Phone Services for July	\$74.91	8/16/2022	
21160	MN Fire Service Cert. Board	Public Safety (FD)	Fire Apparatus Certification Exam for Jared Mackenthun	\$145.00	8/16/2022	
21161	MN Public Facilities Authority	Divided	Bond Debt Service Payment	\$147,734.55	7/26/2022	
21162	MVTL Labs	Sewer	Sewer Ponds Lab Work (3 Samples)	\$252.50	8/16/2022	
21163	North American Safety, Inc.	Public Works	2 Embroidered Safety Shirts	\$50.00	8/16/2022	
21164	Norwood Electric	Hall	Water Heater Hook-up	\$185.50	8/16/2022	
21165	Per Mar Security	Water	Base Alarm Monitoring for WTP 7-24-22 to 10-23-22	\$96.66	8/16/2022	
21166	Runnings Supply	General Gov't Bldgs	Hammer/Impact Drill Kit, 25" Chain, File, Safety Helmet, Gloves	\$593.95	8/16/2022	
21167	Tim Muenzel	Public Safety (FD)	Repairs to Fire Engine 13	\$2,085.00	7/26/2022	
Debit	Security Bank & Trust	Divided	Returned Payment for Utility Bill	\$269.89	7/26/2022	
Debit	Security Bank & Trust	Divided	Returned Payment for Utility Bill - NSF Fee	\$25.00	7/26/2022	
			June Claims	\$211,621.61		
			June Claims	\$44,979.05	6/14/2022	
			June Added Claims	\$167,995.03	7/26/2022	
			June Added Claims	(\$1,352.47)	8/16/2022	
				\$211,621.61		

### 2022 July Claims List

CHECK #	VENDOR	FUND	CLAIM DESCRIPTION	AMOUNT	APPROVED
ACH	EFTPS	Divided	Fed, Social Security, MC - June 2022	\$4,864.16	7/26/2022
ACH	MN Dept. of Revenue	Divided	State Withholding Tax Payment - June 2022	\$993.00	7/26/2022
ACH	MN Dept. of Revenue	Divided	Sales & Use Tax for 2nd Qtr 2022	\$87.00	7/26/2022
ACH	PERA	Divided	PERA Withholding - June 2022	\$839.25	7/26/2022
ACH	PERA	Divided	PERA Withholding - July 2022	\$439.86	7/26/2022
ACH	PERA	Divided	PERA Withholding - July 2022	\$519.21	7/26/2022
ACH	PERA	Divided	PERA Withholding - July 2022	\$558.84	8/16/2022
ACH	PERA	Divided	PERA Withholding - July 2022	\$811.25	8/16/2022
ACH	HealthPartners	Divided	Health Insurance for July 2022	\$1,603.60	7/26/2022
ACH	Optum-Bank	General Gov't	2nd Qtr-2022	\$30.00	7/26/2022
ACH	Brandon Bracht	Divided	Wages 6-13-22 to 6-26-22	\$1,841.02	7/26/2022
ACH	Tamara Bracht	Divided	Wages 6-13-22 to 6-26-22	\$567.29	7/26/2022
ACH	Jeremy Gruenhagen	Divided	June Wages (Rounds)	\$2,205.64	7/26/2022
ACH	Brandon Bracht	Divided	Wages 6-27-22 to 7-10-22	\$1,773.43	7/26/2022
ACH	Tamara Bracht	Divided	Wages 6-27-22 to 7-10-22	\$1,054.42	7/26/2022
ACH	Jeremy Gruenhagen	Divided	July Wages	\$2,119.83	7/26/2022
ACH	Jeremy Gruenhagen	Divided	July Wages	\$2,119.82	8/16/2022
ACH	Brandon Bracht	Divided	Wages 7/11/22 to 7/24/22	\$1,859.21	8/16/2022
ACH	Tamara Bracht	Divided	Wages 7/11/22 to 7/24/22	\$1,147.61	8/16/2022
ACH	Verizon Wireless	General Gov't	City Cell Phone Plan	\$129.05	7/26/2022
ACH	Google	General Gov't	Email Account Service for July 2022	\$168.00	7/26/2022
ACH	MN Dept. of Labor & Industry	Public Safety (FD)	2nd Quarter 2022 Building Permit Surcharge	\$8.22	7/26/2022
ACH	ZOOM	General Gov't	Video Conferencing for June	\$16.09	7/26/2022
ACH	Security Bank & Trust	General Gov't	ACH Service Fees for June 2022	\$30.70	7/26/2022
Debit Card	Amazon	Sewer	Dish Soap	\$16.62	7/26/2022
Debit Card	Amazon	Park & Rec.	Blue Tooth Hearing Protection Headset,	\$84.99	7/26/2022
Debit Card	Amazon	General Gov't	2 Scan Disks for Computer Storage	\$16.59	7/26/2022
Debit Card	Amazon	General Gov't	hp Laserjet Replacement Parts and Ink Cartridge	\$65.87	7/26/2022
Debit Card	Hamburg Post Office	Divided	Postcard Stamps - 10 Rolls	\$480.00	7/26/2022
Debit Card	Amazon	Sewer	Dish Soap	\$15.58	7/26/2022
Debit Card	Amazon	Divided	Batteries for FD, Color Printer Ink, Bathroom Freshne	\$117.71	7/26/2022
21149	CarverLink	Divided	Internet Services for July - City Office, Hall & Park	\$120.00	7/26/2022
21168	Clarke Mosquito	Public Safety	Mosquito Control 2022 (Second of 3 Treatments)	\$1,364.75	7/26/2022
21169	Coordinated Business Systems	General Gov't	Intermedia Monthly Charge Services and Equipment	\$57.16	7/26/2022
21170	ECM Publishing	General Gov't	PT Maintenance Ad	\$504.00	7/26/2022
21171	Gopher State One	Divided	June Locates (10 @ \$1.35)	\$13.50	7/26/2022
21172	Hilger's Plumbing & Heating	Water	Disconnect Temporary Water Supply at 152 Jacob St.	\$525.00	7/26/2022
21173	Johnny Egan	Park & Rec.	Reimbursement for Duck Pond Expenses	\$257.51	7/26/2022
21174	Katie Meyers	Water	Refund of Final Water Bill Over Payment	\$4.61	7/26/2022
21175	Kayla Erickson	Water	Refund of Final Water Bill Over Payment	\$5.64	7/26/2022
21176	Lano Equipment	Public Works	Diagnostic Services for Toolcat	\$243.68	7/26/2022
21177	Loffler Equipment	General Gov't	June Copies	\$81.48	7/26/2022
21178	McLeod Publishing	General Gov't	PT Maintenance Ad	\$393.96	7/26/2022
21179	MNSPECT	Public Safety	Residential Permit HB2022-00003 Re-Roof @ 152 Jacc	\$35.00	7/26/2022
21180	NAPA Auto Parts	Park & Rec.	Oil for Ford Ranger	\$38.65	7/26/2022
21181	News & Times	General Gov't	Annual Subscription Renewal	\$66.35	7/26/2022
21182	Robb's Electric	General Gov't Bldgs	Replaced 2 Photo-Eyes Sensors on Outside Lights	\$272.05	7/26/2022
21183	Security Bank & Trust	Storm Water	Interest - G.O. Public Utility Revenue Bonds, 2019A	\$6,562.50	7/26/2022
21184	Viking Bottling Co.	Hall	Pop Syrup Canisters	\$224.00	7/26/2022
21185	W.W.O.T.A.	Divided	Water/Wastewater Training & Assistance for June 202	\$1,610.12	7/26/2022
21186	Waste Management	Sanitation & Recycl.	30 Yard Flat Green Yard Waste Container	296.04	7/26/2022
21187	Wm. Mueller & Sons	Divided	Fuel for City Vehicle, Lawnmower, & Hawks Lawn Mov	\$378.03	7/26/2022
21188	Xcel Energy	Water	Electricity for Water Tower	\$179.84	7/26/2022
21189	Customized Fire Rescue Training	Public Safety (FD)	Live Burn Training from August, 2021	\$600.00	7/26/2022
21190	Jeremy Gruenhagen	General Gov't	Reimb. for Mileage (Jan-June) & Lunch on Greg's Las	\$248.53	7/26/2022
21191	Canon Financial Services, Inc.	General Gov't	Canon Copoier Gov't Contract for July	\$33.13	7/26/2022
21192	Carver County Sheriff's Office	General Gov't	4.25 Hours Overtime for Deputy Voigt - Assault Inves	\$292.32	7/26/2022
21193	Carver County Attorney's Office	General Gov't	2nd Quarter Fines Collected and Surcharge	\$266.76	7/26/2022
21194	Cintas	Hall	Cleaning Supplies	\$86.51	7/26/2022
21195	Performance Plus (Health Strategies)	Public Safety (FD)	19 Fit Tests and Mask Fittings	\$1,927.50	7/26/2022
21196	Melchert-Hubert & Sjodin, PLLP	General Gov't	Liquor License Matter	\$655.20	7/26/2022
21197	Metronet	Divided	Fiber Phone Service for August	\$75.60	7/26/2022
21198	Mini Biff	Park & Rec.	Handicap Mini Biff Rental with Damage Waiver	\$148.92	7/26/2022
21199	NAPA Auto Parts	Divided	Oil, Filters, Degreaser, Vehicle Wash Detergent, Printe	\$206.70	7/26/2022
21200	Plunkett's Pest Control	Divided	Pest Control at all City Buildings on 7-11-22	\$148.86	7/26/2022
21201	S.E.H.	General Gov't	2022 Street Improvement Project, Review of 4 Project	\$1,156.20	7/26/2022
21202	Wm. Mueller & Sons	Divided	Fuel for City Vehicles and Equipment	\$96.28	7/26/2022
21203	Xcel Energy	Divided	Electricity/Natural Gas Services	\$2,845.92	7/26/2022
				\$48,474.58	
			July Claims	\$42,109.43	7/26/2022
			July Added Claims	\$6,365.15	8/16/2022
				\$48,474.58	

**2022 August Claims List**

CHECK #	VENDOR	FUND	CLAIM DESCRIPTION	AMOUNT	APPROVED
ACH	EFTPS	Divided	Fed, Social Security, MC - July 2021	\$3,645.40	8/16/2022
ACH	MN Dept. of Revenue	Divided	State Withholding Tax Payment - July 2022	\$700.00	8/16/2022
ACH	PERA	Divided	PERA Withholding - August 2022	\$533.10	8/16/2022
ACH	HealthPartners	Divided	Health Insurance for August 2022	\$3,469.06	8/16/2022
ACH	Optum Bank	General Gov't	HSA Admin Fee's for City Employees	\$30.00	8/16/2022
ACH	ZOOM	General Gov't	Audio/Video Conferencing App	\$16.09	8/16/2022
ACH	Google	General Gov't	Email Account Service	\$167.99	8/16/2022
ACH	Security Bank & Trust	General Gov't	ACH Service Fees for July 2022	\$40.90	8/16/2022
ACH	Kwik Trip	General Gov't Bldgs	Non-Ox Gas	\$51.29	8/16/2022
ACH	Kwik Trip	General Gov't Bldgs	Non-Ox Gas	\$49.71	8/16/2022
ACH	Jeremy Gruenhagen	Divided	August Wages	\$2,119.82	8/16/2022
ACH	Brandon Bracht	Divided	Wages	\$1,791.63	8/16/2022
ACH	Tamara Bracht	Divided	Wages	\$1,095.45	8/16/2022
Debit Card	Amazon	Divided	Cell Phone Otterbox Case and Screen Protector	\$75.38	8/16/2022
Debit Card	Amazon	Divided	Flag Gear Rings (Red, Blue)	\$39.16	8/16/2022
Debit Card	Amazon	Divided	6 US Flags	\$233.94	8/16/2022
Debit Card	Amazon	Park & Rec.	Beaded Flag Gear Rings	\$39.90	8/16/2022
Debit Card	Amazon	General Gov't	Fast Chargers for City Cell Phone (Office & Vehicle)	\$27.67	8/16/2022
Debit Card	MN Rural Water Association	Divided	Annual Operator Expo in Waconia	\$150.00	8/16/2022
Debit Card	USPS	General Gov't	EDDM Postage for August Newsletter	\$74.24	8/16/2022
Debit Card	Subway	General Gov't	Lunch for Election Judges	\$73.14	8/16/2022
21230	Voided	Voided	Voided - Printer Damaged Check	Voided	8/16/2022
21231	212 Equipment	General Gov't Bldgs	Weed Whip Line Head, Backpack Sprayer	\$171.98	8/16/2022
21232	ASCAP	Hall	Entertainment License 1-1-22 to 8-14-22	\$20.64	8/16/2022
21233	Brandon Bracht	General Gov't	Mileage Reimbursement for Fire Hydrant Training	\$52.25	8/16/2022
21234	CarverLink	Divided	Internet Services - August	\$120.00	8/16/2022
21235	Cintas	Hall	Cleaning Towels, Dust Mop etc..	\$86.51	8/16/2022
21236	Clarke Mosquito Management	Public Safety	Mosquito Control (Invoice 3 of 3 for 2022 Season)	\$1,364.75	8/16/2022
21237	Coordinated Business Systems	General Gov't	Intermedia Monthly Charge Services and Equipment	\$57.29	8/16/2022
21238	Core & Main	Water	4 IPERL 3/4 Meters	\$620.00	8/16/2022
21239	ECM Publishers Inc.	General Gov't	Part-time Maintenance Worker Ad	\$124.40	8/16/2022
21240	Gopher State One	Divided	6 July Locates	\$8.10	8/16/2022
21241	Home Solutions	Divided	Razorback Shovel, Screws	\$50.03	8/16/2022
21242	Kranz Lawn & Power	Park & Rec.	3 Blades for Exmark Mower, Weed Trimmer Line	\$154.30	8/16/2022
21243	Lano Equipment	Public Works (Streets)	Filters for Bobcat	\$127.55	8/16/2022
21244	Loffler Companies	General Gov't	July Copies	\$46.64	8/16/2022
21245	McLeod Publishing	General Gov't	Part-time Maintenance Worker Ad	\$127.44	8/16/2022
21246	Melchert-Hubert & Sjodin PLLP	General Gov't	Storm Sewer	\$702.00	8/16/2022
21247	Menards	Divided	Cleaning Solutions	\$56.14	8/16/2022
21248	Mid-County Co-op	Divided	Weed Killer	\$363.50	8/16/2022
21249	MN Pump Works	Sewer	Replaced Air Release Valve at Forced Main on Martha St.	\$2,643.40	8/16/2022
21250	MNSPECT, LLC	Public Safety	Building Permits @ 430 RR, 450 Brad, & 830 Park	\$1,232.71	8/16/2022
21251	Monica Trebesch	Public Safety	18 Dozen Cookies for NNO	\$100.00	8/16/2022
21252	Pearson Bros., Inc.	Public Works (Streets)	Seal Coating on Jacob St. & Donald Ave.	\$18,205.92	8/16/2022
21253	Viking Bottling Co.	Park & Rec.	Park Pop Machine	\$648.00	8/16/2022
21254	W.W.O.T.A. Inc.	Divided	Water/Wastewater Training & Assistance for July	\$1,257.50	8/16/2022
21255	Wm. Mueller & Sons	Divided	Fuel for City Vehicles, Mower, BB Mower	\$391.44	8/16/2022
21256	Xcel Energy	Divided	Electricity/Natural Gas Services	\$1,126.47	8/16/2022
				<b>\$44,282.83</b>	



Minnesota Department of Public Safety  
Alcohol and Gambling Enforcement Division  
445 Minnesota Street, Suite 1600, St. Paul, MN 55101  
651-201-7507 Fax 651-297-5259 TTY 651-282-6555  
**APPLICATION AND PERMIT FOR A 1 DAY  
TO 4 DAY TEMPORARY ON-SALE LIQUOR LICENSE**

Name of organization	Date organized	Tax exempt number	
Hamburg Lions	1982		
Address	City	State	Zip Code
	Hamburg	MN	55339
Name of person making application	Business phone	Home phone	
Robert J Gregonis		952.367.7089	
Date(s) of event	Type of organization <input type="checkbox"/> Microdistillery <input type="checkbox"/> Small Brewer		
9/10/22	<input type="checkbox"/> Club <input type="checkbox"/> Charitable <input type="checkbox"/> Religious <input type="checkbox"/> Other non-profit		
Organization officer's name	City	State	Zip Code
Chris Lund	Hamburg	MN	55339
Organization officer's name	City	State	Zip Code
Robert Gregonis	Hamburg	MN	55339
Organization officer's name	City	State	Zip Code
		MN	

Location where permit will be used. If an outdoor area, describe.

Hamburg Community Hall

If the applicant will contract for intoxicating liquor service give the name and address of the liquor license providing the service.

Hamburg Community Hall

If the applicant will carry liquor liability insurance please provide the carrier's name and amount of coverage.

West Bend Mutual Insurance 1 million, DPS 2 million aggregate

APPROVAL

APPLICATION MUST BE APPROVED BY CITY OR COUNTY BEFORE SUBMITTING TO ALCOHOL AND GAMBLING ENFORCEMENT

City or County approving the license	Date Approved
Fee Amount	Permit Date
Date Fee Paid	City or County E-mail Address
	City or County Phone Number

Signature City Clerk or County Official

Please Print Name of City Clerk or County Official

**CLERKS NOTICE: Submit this form to Alcohol and Gambling Enforcement Division 30 days prior to event.**

**ONE SUBMISSION PER EMAIL, APPLICATION ONLY.**

**PLEASE PROVIDE A VALID E-MAIL ADDRESS FOR THE CITY/COUNTY AS ALL TEMPORARY PERMIT APPROVALS WILL BE SENT BACK VIA EMAIL. E-MAIL THE APPLICATION SIGNED BY CITY/COUNTY TO [AGE.TEMPORARYAPPLICATION@STATE.MN.US](mailto:AGE.TEMPORARYAPPLICATION@STATE.MN.US)**

# CITY OF HAMBURG TIME-OFF REQUEST FORM

Today's Date: 07-27-22

Employee Name: Brandon Brauch

Dates Requesting Time-Off: 8-19-22 / 8-20-22  
8-21-22 / 8-22-22

How many **Vacation** hours will be used? 16 - NA

How many **Compensation** hours will be used? \_\_\_\_\_

Is there a **Holiday** during your time off? No

Will there be any time off **without pay**? No

Will there be any scheduled **Sick Leave** used? No

Are you requesting more than three consecutive days off? No

- If yes, you must receive City Council approval.

### City Council Approval

Date of Council Meeting: \_\_\_\_\_

Was vacation request approved? \_\_\_\_\_

- If no, reason request was denied: \_\_\_\_\_

[Signature] 7-27-22  
Employee Signature Date

[Signature] 8-15-22  
City Clerk/Treasurer Date

\_\_\_\_\_  
Mayor Date





# CITY OF HAMBURG TIME-OFF REQUEST FORM

Today's Date: August 15, 2022

Employee Name: Jeremy Gruenhagen

Dates Requesting Time-Off: August 30<sup>th</sup> (Off at 2:30)

How many **Vacation** hours will be used? 0

How many **Compensation** hours will be used? 0

Is there a **Holiday** during your time off? No

Will there be any time off **without pay**? No

Will there be any scheduled **Sick Leave** used? Yes

Are you requesting more than three consecutive days off? No

- If yes, you must receive City Council approval.

### City Council Approval

Date of Council Meeting: \_\_\_\_\_

Was vacation request approved? \_\_\_\_\_

- If no, reason request was denied: \_\_\_\_\_

Jeremy Gruenhagen  
Employee Signature

8-15-22  
Date

\_\_\_\_\_  
City Clerk/Treasurer

\_\_\_\_\_  
Date

\_\_\_\_\_  
Mayor

\_\_\_\_\_  
Date



# JULY DELINQUENCY REPORT 2022

	Acct. #	past due	30 days	60 days	90 days	120 days
	10-02480-01	\$175.17	\$175.17	\$0.00	\$0.00	\$0.00
	10-02490-00	\$101.84	\$101.84	\$0.00	\$0.00	\$0.00
	10-03619-00	\$322.05	\$262.92	\$59.13	\$0.00	\$0.00
	10-05490-00	\$696.08	\$409.89	\$242.90	\$43.29	\$0.00
Payment Plan	10-06190-01	\$146.56	\$146.56	\$0.00	\$0.00	\$0.00
	10-06418-00	\$138.27	\$138.27	\$0.00	\$0.00	\$0.00
Breached	10-07625-00	\$819.77	\$319.84	\$166.34	\$183.85	\$149.74
	10-08321-00	\$105.28	\$105.28	\$0.00	\$0.00	\$0.00
	10-09350-00	\$202.49	\$202.49	\$0.00	\$0.00	\$0.00
Shut off in May	10-09451-00	\$1,928.26	\$178.47	\$121.41	\$132.96	\$1,495.42
	10-10171-00	\$117.99	\$117.99	\$0.00	\$0.00	\$0.00
	10-11851-01	\$173.17	\$173.17	\$0.00	\$0.00	\$0.00
Payment Plan	10-11921-00	\$559.12	\$244.68	\$125.26	\$129.67	\$59.51
	10-14410-00	\$635.18	\$226.06	\$253.73	\$154.70	\$0.69
	10-15821-00	\$155.72	\$155.72	\$0.00	\$0.00	\$0.00
	10-17621-00	\$375.82	\$372.12	\$3.70	\$0.00	\$0.00

<b>Total Past Due</b>	<b>\$6,652.77</b>
-----------------------	-------------------

\$3,330.47
\$972.47
\$644.47
\$1,705.36



Dear MRWA Member,

The ServLine Leak Protection Program, an Affinity Partner with the Minnesota Rural Water Association and a member of the NRWA Products & Services Portfolio, provides financial protection to utilities for losses from customer water leaks. The program also educates homeowners about their water loss responsibilities and gives utilities an opportunity to provide help for families to manage a large, unexpected expense.

Benefits to utilities include:

- Recapture lost revenue and bad debt associated with water leaks
- Lowers utility costs
- Reduces and simplifies staff workload
- Increases customer satisfaction

Benefits to customers:

- Financial protection from excess water bill
- No deductible
- Affordable rates
- Seamless processing of claims
- Customers are provided with a 24/7/365 hotline with live agents

ServLine is part of HomeServe USA, a leading provider of home repair solutions in North America, with an outstanding national reputation and is A+ rated with the BBB. HomeServe has more than 4.8 million customers across the U.S. and Canada. HomeServe also has long-standing relationships with the National League of Cities and multiple state leagues.

There are 201 rural municipalities and water utilities currently partnered with ServLine that have saved more than \$22 million over the past seven years. The program is supported by the National Rural Water Association and multiple State Rural Water Associations.

For more information, please contact Angie Southers from ServLine. She can be reached at [angie.southers@homeserveusa.com](mailto:angie.southers@homeserveusa.com) and 347-957-2689. Their website is [www.servline.com](http://www.servline.com).

Sincerely,

A handwritten signature in black ink that reads "Lori Blair".

Lori Blair, Executive Director  
Minnesota Rural Water Association

# Activity/Project List Deputy Clerk

## AUGUST 1 - 31, 2022

*Daily Duties = Bank, Post Office, Enter Water Payments, Enter Bills*

<b>Monday - 1st</b> 8.75 Hours	Daily Duties, set up for NNO
<b>Tuesday - 2nd</b> 11.25 Hours	Daily Duties, Ran Water Bills and Reports, NNO
<b>Wednesday - 3rd</b> 8.5 Hours	Jeremy - Off, Daily Duties, sent Water bills out, Entered receipts in QB
<b>Thursday - 4th</b> 5 Hours	Daily Duties, toured town for Nuisance Violations/pictures, started final nuisance letters, Brought NNO supplies to office from park, Personnel Meeting
<b>Friday - 5th</b> 7.5 Hours	Daily Duties, completed final nuisance letters and mailed
<b>Monday - 8th</b> 8.5 Hours	Daily Duties, Entered Bills, Updated Claims List, Election Set-up
<b>Tuesday - 9th</b> 15.5 Hours	Primary Elections, Newsletter
<b>Wednesday - 10th</b> 7.75 Hours	Daily Duties, prepped mailing envelopes,
<b>Thursday - 11th</b> 2.25 Hours	Daily Duties, mailed out bill payments, left early (10:15)
<b>Friday - 12th</b> 7 Hours	Jeremy off - Worked through payroll issue, Prepared Agenda, left at 3:30
<b>Monday - 15th</b> Hours	Daily Duties, Updated Nuisance Spreadsheet and Delinquency Report for Council, Staff meeting, Updated Council Binder, Filed away Election Info. and other misc. reports
<b>Tuesday - 16th</b> Hours	
<b>Wednesday - 17th</b> Hours	
<b>Thursday - 18th</b> Hours	
<b>Friday - 19th</b> Hours	
<b>Monday - 22nd</b> Hours	
<b>Tuesday - 23rd</b> Hours	
<b>Wednesday - 24th</b> Hours	
<b>Thursday - 25th</b> Hours	OFF
<b>Friday - 26th</b> Hours	OFF
<b>Monday - 29th</b> Hours	
<b>Tuesday - 30th</b> Hours	
<b>Wednesday - 31st</b> Hours	

**Public Employees Retirement Association of Minnesota**

60 Empire Drive, Suite 200  
St. Paul, MN 55103-2088  
Phone: 651-296-7460 or 1-800-652-9026  
Website: [www.mnpera.org](http://www.mnpera.org)



July 11, 2022

PERA ID:  
5074-00

Governing Body and Fire Chief  
Hamburg Fire Department

[cityadmin@cityofhamburgmn.com](mailto:cityadmin@cityofhamburgmn.com); [chief1@cityofhamburgmn.com](mailto:chief1@cityofhamburgmn.com)

In accordance with Minnesota Statutes 353G.08, we have determined the 2023 required contribution to cover your volunteer firefighters enrolled in the statewide volunteer firefighter plan. Any amount payable is due to PERA before December 31, 2023. Please refer to attached schedules for detailed information regarding the calculations.

Service Pension Level:	\$1,800
Overall Funding Balance For Current Calendar Year	\$136,846
Funding Ratio	127%
This account is considered to have:	Surplus Over Full Funding

Financial Requirement at 12/31/2023	\$27,987
Reductions to the Financial Requirement:	(\$53,365)

**Required Contribution Due by 12/31/2023**

**None**

Contributions to the statewide volunteer firefighter plan above and beyond any required contributions may be made at any time. Please contact me if you would like to make a voluntary contribution to your plan account.

On behalf of the statewide volunteer firefighter plan advisory board, I hereby direct you to distribute this report to your membership.

If you have any questions, please do not hesitate to contact me by phone (651-201-2666) or by email ([sharyn.north@mnpera.org](mailto:sharyn.north@mnpera.org)).

Sincerely,

A handwritten signature in cursive script that reads "Sharyn North".

Sharyn North  
Accounting Officer Principal, PERA

**Public Employees Retirement Association of Minnesota**

60 Empire Drive, Suite 200  
St. Paul, MN 55103-2088  
Phone: 651-296-7460 or 1-800-652-9026  
Website: [www.mnpera.org](http://www.mnpera.org)



August 4, 2022

PERA ID:  
5074-00

Fire Chief  
Hamburg Fire Department

PERA created this Annual Funding report using modified membership assumptions to show the impact of certain member benefit payouts on the funding ratio. These modified member assumptions are theoretical and do not reflect actual member benefit payouts.

Service Pension Level:	\$1,800
Overall Funding Balance For Current Calendar Year	\$136,906
Funding Ratio	135%
This account is considered to have:	Surplus Over Full Funding
Financial Requirement at 12/31/2023	\$24,321
Reductions to the Financial Requirement:	(\$46,889)
<b>Required Contribution Due by 12/31/2023</b>	<b>None</b>

**Public Employees Retirement Association of Minnesota**  
 60 Empire Drive, Suite 200  
 St. Paul, MN 55103-2088  
 Phone: 651-296-7460 or 1-800-652-9026  
 Website: www.mnpera.org



August 4, 2022

PERA ID  
5074-00

Governing Body and Fire Chief  
Hamburg Fire Department

[cityadmin@cityofhamburgmn.com](mailto:cityadmin@cityofhamburgmn.com), [chief1@cityofhamburgmn.com](mailto:chief1@cityofhamburgmn.com)

We received your request for an analysis to estimate the cost of increasing your organization's pension benefit level in the Statewide Volunteer Firefighter Plan administered by PERA. Using current information, we analyzed the cost of the pension benefit level(s) you requested. The results of our analysis, including the estimated required contribution, are shown below.

A. Benefit Level (per year of service):	\$ 2,000	\$ 2,200	\$ 2,400	\$ 2,600
B. Projected Present Assets 12/31/2022 [Attached]	553,920	553,920	553,920	553,920
C. Accrued Liability 12/31/2022 [Attached]	544,593	585,971	627,283	668,630
D. Surplus/ (Deficit) [B-C]	9,327	(32,051)	(73,363)	(114,710)
E. Funding Ratio at 12/31/2022 [B/C]	<b>102%</b>	<b>95%</b>	<b>88%</b>	<b>83%</b>
F. Accrued Liability 12/31/2023[Attached]	589,551	635,114	680,603	726,125
G. Annual Financial Requirement: Increase in Liability [F -C]	44,958	49,143	53,320	57,495
H. Annual Financial Requirement: PERA Fees [\$30/member]	900	900	900	900
I. Annual Financial Requirement: 1/10th of Deficit/(Surplus) [D/10]	(933)	3,205	7,336	11,471
J. Annual Financial Requirement: Total [G+H+I] 12/31/2023	44,925	53,249	61,556	69,866
K. Reductions to Annual Financial Requirement:				
Projected 2023 Annual Fire State Aid [2022 Amount @1.035]	14,962	14,962	14,962	14,962
Projected 2023 Investment Earnings [6% on Projected Assets 12/31/2022]	33,235	33,235	33,235	33,235
<b>L. Estimated Required Contribution [J-K]</b>	<b>None</b>	<b>\$ 5,052</b>	<b>\$ 13,360</b>	<b>\$ 21,669</b>

Please note that this report reflects **estimates**. The figures shown above on Line L are **estimates** of required contributions that would be due on December 31, 2023 and beyond at the applicable benefit level(s).

These estimates are based on the member information available at the time PERA prepared this analysis.

Please review the member information and provide PERA with any corrections to this information.

If applicable, we will prepare an updated cost analysis for your organization using the corrected member information provided.

If you have questions, please contact me at [gemma.miltich@mnpera.org](mailto:gemma.miltich@mnpera.org) or by phone at 651-201-2645.

Sincerely,

Gemma Miltich  
Accounting Officer, PERA

Public Employees Retirement Association of Minnesota  
 60 Empire Drive, Suite 200  
 St. Paul, MN 55103-2088  
 Phone: 651-296-7460 or 1-800-652-9026  
 Website: www.mnpera.org



August 4, 2022

PERA ID  
 5074-00

Governing Body and Fire Chief  
 Hamburg Fire Department

[cityadmin@cityofhamburgmn.com](mailto:cityadmin@cityofhamburgmn.com); [chief1@cityofhamburgmn.com](mailto:chief1@cityofhamburgmn.com)

**PERA created this cost analysis using modified membership assumptions to show the impact of certain membership benefit payouts on the funding ratios. These modified member assumptions are theoretical and do not reflect actual member benefit payouts.**

A. Benefit Level (per year of service):	\$ 2,000	\$ 2,200	\$ 2,400	\$ 2,600
B. Projected Present Assets 12/31/2022 [Attached]	443,220	443,220	443,220	443,220
C. Accrued Liability 12/31/2022 [Attached]	424,593	453,971	483,283	512,630
D. Surplus/ (Deficit) [B-C]	18,627	(10,751)	(40,063)	(69,410)
E. Funding Ratio at 12/31/2022 [B/C]	<b>104%</b>	<b>98%</b>	<b>92%</b>	<b>86%</b>
F. Accrued Liability 12/31/2023[Attached]	465,551	498,714	531,803	564,925
G. Annual Financial Requirement: Increase in Liability [F -C]	40,958	44,743	48,520	52,295
H. Annual Financial Requirement: PERA Fees [\$30/member]	840	840	840	840
I. Annual Financial Requirement: 1/10th of Deficit/(Surplus) [D/10]	(1,863)	1,075	4,006	6,941
J. Annual Financial Requirement: Total [G+H+I] 12/31/2023	39,935	46,659	53,366	60,076
K. Reductions to Annual Financial Requirement:				
Projected 2023 Annual Fire State Aid [2022 Amount @1.035]	14,962	14,962	14,962	14,962
Projected 2023 Investment Earnings [6% on Projected Assets 12/31/2022]	26,593	26,593	26,593	26,593
L. Estimated Required Contribution [J-K]	None	\$ 5,104	\$ 11,812	\$ 18,521



# My first 100 days

Things I need to be successful

# ABOUT ME, WHAT I'VE LEARNED, MISTAKES I'VE MADE

- About Me
- What I've Learned
- Mistakes I've made
- How I'm starting at a disadvantage

Things the city  
needs that we  
don't currently  
have

# Tools



**This is a list of some of the tools which will enable me to safely perform key functions of this role in an efficient way (time & cost savings)**

On the printout which I'll hand out after my presentation you'll find a list of critical tools which are needed for me to be safe and successful in this role. I've narrowed these down to the most important.

I'll walk you through an example now where I'll show the ROI in a single tool.



# Trailer

A trailer would provide lots of time savings for me when performing grounds keeping duties.

I'll walk you through an example of how a trailer would benefit me, and thus the city, in this role and how it would help with making things much more efficient.

# Truck

The City of Hamburg currently has two trucks. One truck is a 2011 Ford Ranger ¼ ton. This truck has been in need of a new transmission, as well as some suspension repairs, which would cost much more than it's current worth (Approx 3-\$5k in repairs). The other is a late 90's ½ ton Chevy truck with a dump bed that needs as much repair as the Ranger.

The Ranger is also not conducive for me to perform the day-to-day functions of this role.

An example of this:

I spend around 2 hours per day running back and forth between the shop and various places in town to pickup, load, return and unload various tools needed for the job. (this equates to approx. \$13k per year in wages to me spent going back and forth and loading/unloading). There simply isn't enough room in the truck to take the needed tools with me at the start of the day which I might need throughout the day. Other cities leverage ½ - ¾ ton trucks with utility boxes which they actually keep the most frequently used tools in the truck box so that they have them available when needed.

If the Council already hasn't done so, the council should really consider selling the two old trucks and purchasing a new or newer ½ ton or larger truck with a utility bed as part of the 2023 budget.

# Thank you!

- Recap of what the City needs for me to be successful in this role.
- I realize that some/most of this may be unexpected. That said, these aren't new needs. The trucks have been in poor condition for a long time. Greg didn't ask for a trailer as he was content with driving the lawn mower back and forth.
- I don't have access to the same tools that Greg had, and I can't use my own tools – nor should I have to. I had no idea what tools I was stating with until Greg left.
- I need your help to help me be successful.

Ⓢ Health Insurance





## A quote for your consideration

Based on your business needs, we put the following quote together to help with your purchase decision. Below is a detailed summary of the quote we've created to help you with your purchase decision.

To proceed with this quote, you may respond to this email, order online through your [Premier page](#), or, if you do not have Premier, use this [Quote to Order](#).

<b>Quote No.</b>	<b>3000127474508.1</b>	Sales Rep	Hannah Thoms
<b>Total</b>	<b>\$1,783.92</b>	Phone	(800) 456-3355, 6179079
Customer #	530027575207	Email	Hannah_Thoms@Dell.com
Quoted On	Jul. 27, 2022	<b>Billing To</b>	ACCOUNTS PAYABLE
Expires by	Aug. 26, 2022		CITY OF HAMBURG
Contract Name	Dell NASPO Computer		PO BOX 248
	Equipment PA - Minnesota		HAMBURG, MN 55339-0248
Contract Code	C000000012056		
Customer Agreement #	MNWNC-108 / 97222		
Deal ID	24242469		

### Message from your Sales Rep

Please contact your Dell sales representative if you have any questions or when you're ready to place an order. Thank you for shopping with Dell!

Regards,  
Hannah Thoms

---

### Shipping Group

<b>Shipping To</b>	<b>Shipping Method</b>
BRANDON BRACHT CITY OF HAMBURG 181 BROADWAY AVE HAMBURG, MN 55339-9405 (952) 467-3232	Standard Delivery Free Cost

Product	Unit Price	Quantity	Subtotal
Dell Latitude 5430 Rugged	\$1,783.92	1	\$1,783.92
	<b>Subtotal:</b>		\$1,783.92
	<b>Shipping:</b>		\$0.00
	<b>Environmental Fee:</b>		\$0.00
	<b>Non-Taxable Amount:</b>		\$1,783.92
	<b>Taxable Amount:</b>		\$0.00
	<b>Estimated Tax:</b>		\$0.00
	<b>Total:</b>		\$1,783.92

## Shipping Group Details

### Shipping To

BRANDON BRACHT  
CITY OF HAMBURG  
181 BROADWAY AVE  
HAMBURG, MN 55339-9405  
(952) 467-3232

### Shipping Method

Standard Delivery Free Cost

	Quantity	Subtotal
<b>Dell Latitude 5430 Rugged</b>	<b>1</b>	<b>\$1,783.92</b>
Estimated delivery if purchased today: Aug. 29, 2022 Contract # C000000012056 Customer Agreement # MNWNC-108 / 97222		

Description	SKU	Unit Price	Quantity	Subtotal
Dell Latitude 5430 Rugged	210-BCFW	-	1	-
Intel Core Processor i5-1135G7, (QC, 2.4 to 3.8 GHz, 28W, non-vPro)	379-BERT	-	1	-
Windows 11 Pro, English, French, Spanish	619-AQLP	-	1	-
No Microsoft Office License Included – 30 day Trial Offer Only	658-BCSB	-	1	-
Intel® Core™ non-vPro i5-1135G7 with Iris Xe Graphics	338-CCRK	-	1	-
ME Lockout MOD - Manageability	631-ADED	-	1	-
8GB, 1x8GB, 3200 MHz DDR4 Non-ECC	370-AGTF	-	1	-
256GB M.2 PCIe NVMe Class 35 Solid State Drive	400-BMSB	-	1	-
14" Non-touch 400 nits WVA FHD (1920 x 1080) 100% sRGB Anti-Glare	391-BGGF	-	1	-
Rubberized English US keyboard	583-BILS	-	1	-
Intel AX210 WLAN Driver	555-BHCC	-	1	-
Intel AX210 Wireless Card with Bluetooth	555-BHCH	-	1	-
Hot surface warning label	389-ECGC	-	1	-
Primary 3 Cell 53.5 Whr ExpressCharge Capable Battery	451-BCWC	-	1	-
90W 461G Type-C EPEAT Adapter	492-BDEL	-	1	-
No Fingerprint, no Smartcard reader	346-BHQQ	-	1	-
Power Cord 1M US	450-AAEJ	-	1	-
Setup and Features Guide	340-CXCE	-	1	-
Dummy Airbay Cover	325-BEIV	-	1	-
ENERGY STAR Qualified	387-BBPC	-	1	-
Custom Configuration	817-BBBB	-	1	-
Dell Applications for Windows 11	658-BFIP	-	1	-
Mix Ship, Notebook, 5430 Rugged	340-CYJC	-	1	-
Foxit PDF Editor	634-BYVC	-	1	-
Microphone + RGB HD camera; Non-touch; WLAN/WWAN antennae; Pogo vehicle docking and RF passthrough	319-BBHS	-	1	-
EPEAT 2018 Registered (Silver)	379-BDTO	-	1	-
No Option Included	340-ACQQ	-	1	-
Additional USB-A rear port	590-TFHR	-	1	-

Additional TBT/Type-C port	325-BEJZ	-	1	-
Rigid handle	750-ADPK	-	1	-
ProSupport Plus: Next Business Day Onsite, 3 Years	808-6797	-	1	-
Dell Limited Hardware Warranty Initial Year	808-6805	-	1	-
ProSupport Plus: Accidental Damage Service, 3 Years	808-6817	-	1	-
ProSupport Plus: Keep Your Hard Drive, 3 Years	808-6818	-	1	-
ProSupport Plus: 7X24 Technical Support, 3 Years	808-6847	-	1	-
Thank you for choosing Dell ProSupport Plus. For tech support, visit www.dell.com/contactdell or call 1-866-516-3115	997-8367	-	1	-

<b>Subtotal:</b>	<b>\$1,783.92</b>
<b>Shipping:</b>	<b>\$0.00</b>
<b>Environmental Fee:</b>	<b>\$0.00</b>
<b>Estimated Tax:</b>	<b>\$0.00</b>
<hr/>	
<b>Total:</b>	<b>\$1,783.92</b>



Jeremy Gruenhagen &lt;cityadmin@cityofhamburgmn.com&gt;

---

## Mike Royal Solar Install Proposal

---

**Harry Davis** <Harry.Davis@bolton-menk.com>

Thu, Jul 7, 2022 at 4:09 PM

To: Jeremy Gruenhagen &lt;cityadmin@cityofhamburgmn.com&gt;

Cc: Chris Lund &lt;clund@cityofhamburgmn.com&gt;, Eric Poppler &lt;epoppler@cityofhamburgmn.com&gt;, Jason Buckentin &lt;jbuckentin@cityofhamburgmn.com&gt;, Jessica Weber &lt;jweber@cityofhamburgmn.com&gt;, Tim Tracy &lt;ttracy@cityofhamburgmn.com&gt;

Jeremy,

Based on what I see in zoning code, all solar systems are permitted as accessory uses when combined with a principal use. In this case, it looks like the principal use is the house and the solar panels are accessory to it. There are no additional code restrictions for the number of panels, amount of area covered, etc.

Even though that is a lot of panels, it looks like it would be allowed by zoning code.

Harry

**Harry Davis, AICP**

Planner II

**Bolton & Menk, Inc.**[12224 Nicollet Avenue](#)[Burnsville, MN 55337](#)

Mobile: 952.529.0053

**[Bolton-Menk.com](#)**

---

**From:** Jeremy Gruenhagen <cityadmin@cityofhamburgmn.com>**Sent:** Thursday, July 7, 2022 11:27 AM**To:** Harry Davis <Harry.Davis@bolton-menk.com>**Cc:** Chris Lund <clund@cityofhamburgmn.com>; Eric Poppler <epoppler@cityofhamburgmn.com>; Jason Buckentin <jbuckentin@cityofhamburgmn.com>; Jessica Weber <jweber@cityofhamburgmn.com>; Tim Tracy <ttracy@cityofhamburgmn.com>**Subject:** Fwd: Mike Royal Solar Install Proposal

Harry,

We have a resident at 420 Henrietta that wants to install over 50 Solar Panels on his property/home. I've attached the proposal below.

Is this something that would be allowed per City Zoning Code/Ordinances?

I have a feeling this might upset a few neighbors & not sure I or the Council would be fans of this proposal.



Jeremy Gruenhagen <cityadmin@cityofhamburgmn.com>

---

## Mike Royal Solar Install Proposal

---

Harry Davis <Harry.Davis@bolton-menk.com>  
To: Jeremy Gruenhagen <cityadmin@cityofhamburgmn.com>

Fri, Aug 5, 2022 at 9:59 AM

Jeremy,

Yes, solar panels are not required to be on the house. The major limitation I see is that you can't have only solar panels as the principal use of the property.

Harry

**Harry Davis, AICP**

Planner II

**Bolton & Menk, Inc.**

12224 Nicollet Avenue

Burnsville, MN 55337

Mobile: 952.529.0053

**Bolton-Menk.com**

---

**From:** Jeremy Gruenhagen <cityadmin@cityofhamburgmn.com>  
**Sent:** Friday, August 5, 2022 9:34 AM  
**To:** Harry Davis <Harry.Davis@bolton-menk.com>  
**Subject:** Re: Mike Royal Solar Install Proposal

Harry,

If the solar panels are being placed on the garage (not home) and the property, does this still meet city zoning regulations?

Thanks,

**Jeremy Gruenhagen**

*City Clerk-Treasurer*



Jeremy Gruenhagen &lt;cityadmin@cityofhamburgmn.com&gt;

**RE: Liquor Licenses [MHS-45791]****Christophe Morschen** <cmorschen@mhslaw.com>

Wed, Jul 27, 2022 at 4:08 PM

To: Jeremy Gruenhagen &lt;cityadmin@cityofhamburgmn.com&gt;

Cc: Kelly Dohm &lt;kdohm@mhslaw.com&gt;, Jacob Saufley &lt;jsaufley@mhslaw.com&gt;

Jeremy,

You are correct that the new ordinance would allow the HBC to apply for a strong beer/wine license under the new provision in the statute. No public hearing is required for the ordinance, only public notice that the City Council will be considering the matter as with any other proposed ordinance.

For Parkside's fundraiser a street obstruction permit would be required for blocking off the sidewalk and the street. Then there are a couple of options regarding the service of liquor:

One possibility would be for Parkside to request authorization (the statutes and the ordinance don't call it a permit) to dispense liquor off-premises for the fundraiser as a "community festival", under Hamburg Code § 112.22 and MN ST § 340A.404 Subd.4(b). Because this procedure allows the City to approve the sale and consumption of alcohol within a certain area, here a specified and fenced area of the street, I believe this would satisfy the requirements of Hamburg's public consumption ordinance.

The other option I see would require the City to amend its liquor ordinances to create the option for permitting the consumption of alcohol in public spaces and streets, since the current public consumption ordinance prohibits the consumption of alcohol in streets or on sidewalks except "where the consumption and display of liquor is lawfully permitted". A caterer's permit from the Commissioner would allow Parkside to serve liquor off their licensed premises, but it doesn't provide an avenue for the City to permit consumption on the street.

Best,

**Christophe Morschen**  
Associate Attorney

Melchert Hubert Sjodin, PLLP

(952) 442-7798

[cmorschen@mhslaw.com](mailto:cmorschen@mhslaw.com)

Attorneys at Law

[www.mhslaw.com](http://www.mhslaw.com)

121 West Main Street; Suite 200, Waconia, MN 55387

This email may contain confidential information. If you are not the intended recipient, please delete this email and notify me. Thank you.



Jeremy Gruenhagen &lt;cityadmin@cityofhamburgmn.com&gt;

---

**RE: Liquor Licenses [MHS-45791]**

---

**Christophe Morschen** <cmorschen@mhslaw.com>

Thu, Jul 28, 2022 at 11:08 AM

To: Jeremy Gruenhagen &lt;cityadmin@cityofhamburgmn.com&gt;

Cc: Jacob Saufley &lt;jsaufley@mhslaw.com&gt;, Kelly Dohm &lt;kdohm@mhslaw.com&gt;

Jeremy,

I will put together a checklist with the steps to make the amendment. We've also been fine-tuning some of the language in the proposed ordinance amendment. We'll send the new language over to you when it's ready.

Because the City posts ordinances to its website, the proposed ordinance needs to be posted on the website 10 days prior to the city council meeting when the vote on the proposed ordinance will take place. If the City has an email newsletter, it should also include a notice that there is a proposed ordinance amendment in that email. This notice and the proposed ordinance can go in the City Info/Permits section of the website where the other news bulletins get posted.

Yes, once the ordinance is adopted, it needs to be published in the official newspaper.

Do you know if the HBC's lease for the baseball field was formally renewed this year? Also, do you know how many more home games do the Hawks play this season?

**Christophe Morschen**  
Associate Attorney

Melchert Hubert Sjodin, PLLP

**Attorneys at Law**

(952) 442-7798

[cmorschen@mhslaw.com](mailto:cmorschen@mhslaw.com)[www.mhslaw.com](http://www.mhslaw.com)

121 West Main Street; Suite 200, Waconia, MN 55387

This email may contain confidential information. If you are not the intended recipient, please delete this email and notify me. Thank you.

**From:** Jeremy Gruenhagen <cityadmin@cityofhamburgmn.com>**Sent:** Wednesday, July 27, 2022 4:44 PM**To:** Christophe Morschen <cmorschen@mhslaw.com>**Subject:** Re: Liquor Licenses



Jeremy Gruenhagen &lt;cityadmin@cityofhamburgmn.com&gt;

**RE: Liquor Licenses [MHS-45791]****Christophe Morschen** <cmorschen@mhslaw.com>

Tue, Aug 2, 2022 at 12:10 PM

To: Jeremy Gruenhagen &lt;cityadmin@cityofhamburgmn.com&gt;

Cc: Kelly Dohm &lt;kdohm@mhslaw.com&gt;, Jacob Saufley &lt;jsaufley@mhslaw.com&gt;

Thank you Jeremy,

As I mentioned in my previous email, now would be as good a time as any to amend the public consumption ordinance to allow permits if that's the way that the City wants handle this situation.

If the City wants Parkside to use a caterer's permit then an amendment is required to create an avenue for an area where consumption and display of alcohol is permitted by law in public. Initially I expect the language would create a type of permit for applicants to request permission to consume, display, and serve alcohol outside of their licensed premises and in the public street or sidewalk. It would require them to set out the proposed location and prove their insurance, which would be considered by the City Council on a single-event basis. That way this would not be any blanket authorization to sell and consume in public. This route also requires that Parkside holds a caterer's permit from the State. Parkside would still need to receive a street obstruction permit.

-

On the other hand, if the City wanted this to be handled as a "community festival" under Hamburg Code § 112.22 and MN ST § 340A.404 Subd.4(b) no further amendments to the code would be necessary. Parkside (or any other licensee if applicable) would need to apply to the City for permission to serve alcohol outside of their licensed premises and would need to specify the area in which the liquor will be consumed. This would be a one-time application, and the "community festival" need not be a city sponsored event so the City's involvement could be limited to considering the request and the street obstruction permit.

Under either of these scenarios, the street obstruction permit would be required. This is convenient because it allows the City Council to require the applicant to provide proof that their activities will be insured to protect the City from liability for this banquet. Hamburg Code § 91.23 requires every street obstruction permit application to include a certificate of insurance, and § 91.24 allows the City to require conditions on the obstruction permit such as an agreement under which Parkside would take liability for any accidents or other occurrences the event.

Feel free to call me if you have any questions about this. I have a meeting this afternoon, but I will be free at about 3PM.

**Christophe Morschen**  
Associate Attorney

Melchert Hubert Sjodin, PLLP

(952) 442-7798

[cmorschen@mhslaw.com](mailto:cmorschen@mhslaw.com)



Attorneys at Law

[www.mhslaw.com](http://www.mhslaw.com)



2022

Nuisance Violations  
August Follow-up

Name/Occupant	Grams, Paul	Howe	Proskin	Gregonis	Tollefson	Chadwick	Zachary Wilson
Date of Complaint	5/12/2022	5/12/2022	5/12/2022	5/12/2022	5/12/2022	5/12/2022	8/5/2022
Address	410 Sophia Ave.	625 Kim Ave.	619 David Ave.	320 Sophia Ave.	Maria Ave.	679 Park Ave.	152 Jacob St.
City of Hamburg Ordinance #	93.18	93.18	93.18	93.18	93.18	93.18	93.19
	93.19					93.20	
	93.20					93.21	
Nature of Complaint	City Spring Inspection	City Spring Inspection	City Spring Inspection	City Spring Inspection	City Spring Inspection	City Spring Inspection	City Spring Inspection
Date Mailed	5/12/2022	5/12/2022	5/12/2022	5/12/2022	5/12/2022	5/12/2022	8/5/2022
Date to Follow-up	6/13/2022	6/13/2022	6/13/2022	6/13/2022	6/13/2022	6/13/2022	8/16/2022
Council Meeting Date	6/14/2022	6/14/2022	6/14/2022	6/14/2022	6/14/2022	6/14/2022	8/16/2022
Declared Public Nuisance	6/14/2022	6/14/2022	6/14/2022		6/14/2022		
Date Posted	6/30/2022	6/30/2022	6/30/2022		6/30/2022		
Date to comply	7/25/2022 8/15/2022	7/25/2022 8/15/2022	7/25/2022 8/15/2022		7/25/2022 8/15/2022	7/25/2022 8/15/2022	
Date Sent to Prosecution							
Notes							

93.18 Nuisance Affecting Peace and Safety  
93.19 Nuisance Parking and Storage  
93.20 Inoperable Motor Vehicle  
93.21 Building Maintenance and Appearance

95.02 Dogs and Cats

Keep an eye on garage siding and general yard cleanup too many sheds?  
Called - house sale is almost finalized. Will complete clean-up by end of month.  
he attended council meeting - said he would take care of everything  
She called and may attend council meeting to get direction

08/15/22  
06/14/22  
08/08/22



Jeremy Gruenhagen <cityadmin@cityofhamburgmn.com>

## CarverLink Fiber Diversity at B10 Hamburg City Hall

2 messages

**Randy Lehs - CarverLink** <rlehs@carverlink.com>  
Reply-To: rlehs@carverlink.com  
To: Jeremy Gruenhagen <cityadmin@cityofhamburgmn.com>  
Cc: Randy Lehs - CarverLink <rlehs@carverlink.com>

Mon, Aug 8, 2022 at 1:30 PM

Jeremy,

I'm exploring getting some fiber diversity for the network room we have located in your Hamburg City Hall. This location is one of what we call our Hub locations for our ring and currently we have a single point of failure vulnerability with the 300ft or so fiber cable that runs from the road into the building. I'm potentially looking to construct a diverse route around the building. Would the City have any issues with us installing a line (we would locate everything of course before doing anything) that would follow the relative route I have shown in my yellow line below?

Randy



Randy Lehs | CarverLink Fiber Manager



Jeremy Gruenhagen &lt;cityadmin@cityofhamburgmn.com&gt;

---

**Parcel 45.0750061**

---

Harry Davis <Harry.Davis@bolton-menk.com>  
To: Jeremy Gruenhagen <cityadmin@cityofhamburgmn.com>

Fri, Apr 8, 2022 at 1:43 PM

Jeremy,

Sorry for the delay in getting back to you. I looked through the code and it doesn't say that you couldn't combine two properties, but I am worried about the idea of combining two parcels that don't share a property line. I think there needs to be a fine line between combining parcels across ROW (alley only? Alley and street?) and combining parcels across the city. I think there are two real options:

1. You don't allow properties to be combined when divided by ROW (unless their property lines touch underneath ROW). – My recommendation.

This makes sense from one viewpoint- you can't actually combine parcels when they are divided by ROW that is owned by the City. Perhaps this could be different if the parcels "owned" underneath the ROW and touched each other, but in both cases I don't think that applies. The plats for both subdivisions very clearly dedicated ROW and defined the parcel boundaries.

2. You allow properties that are directly adjacent to each other across ROW to be combined.

The situation I saw in Eyota was an existing non-conformity, so it doesn't exactly apply, but they had an alley that divided the property between a principal structure and a garage. Eventually they decided they wanted to make it into two parcels again, which makes me hesitate recommending this for Hamburg. Say you combine them and an accessory structure is built, what method do you have of making sure the garage is torn down or moved if that property owner wishes to sell either part of the combined parcel? It makes the process messier. If you do decide to move forward with this, I recommend only allowing parcels that are directly across from each other via alley ROW to be combined. You could also include streets, but I think there is a difference between properties across alleys and streets in terms of continuity between both parts of the parcel.

Happy to call and talk about this more.

Harry

**Harry Davis, AICP**

Planner II

**Bolton & Menk, Inc.**

12224 Nicollet Avenue

Burnsville, MN 55337



Jeremy Gruenhagen &lt;cityadmin@cityofhamburgmn.com&gt;

---

**Parcel 45.0750061**

---

Harry Davis <Harry.Davis@bolton-menk.com>  
To: Jeremy Gruenhagen <cityadmin@cityofhamburgmn.com>

Wed, Jul 6, 2022 at 4:31 PM

Jeremy,

I took a stab at a draft piece of code that I wanted to run by you first before putting a more formal memo together.

My thought is to place the new code here:

## Chapter 160B Subdivision Ordinance

### Section F. Subdivision Design Standards

#### Subdivision 1. General

E. When combining parcels through a Minor Subdivision process:

1. The applicant may propose and the city may approve a combination of parcels separated by either an easement or alleyway, only if:

- a. One or more of the existing parcels is not currently considered a buildable lot.
- b. The resulting parcel(s) may not revert to the prior configuration after completion of the Minor Subdivision.
- c. The resulting parcel(s) will meet all zoning requirements, and no future actions will create nonconforming uses, buildings, or lots.
- d. The applicant meets all Minor Subdivision requirements, including procedures in Section D, Subd. 2 of this Chapter.

I considered putting it under Section D, Subd. 2 with the Minor Subdivision procedure, but I figure that all subdivisions needed to adhere to general requirements found under Section F, so this may work better. Happy to talk about this more before this goes to the July 26<sup>th</sup> meeting.

Harry

**Harry Davis, AICP**

Planner II

**Bolton & Menk, Inc.**[12224 Nicollet Avenue](#)



Jeremy Gruenhagen <cityadmin@cityofhamburgmn.com>

**Parcel 45.0750061**

Harry Davis <Harry.Davis@bolton-menk.com>

Tue, Aug 16, 2022 at 12:18 PM

To: Jeremy Gruenhagen <cityadmin@cityofhamburgmn.com>

Cc: Chris Lund <clund@cityofhamburgmn.com>, Eric Poppler <epoppler@cityofhamburgmn.com>, Jason Buckentin <jbuckentin@cityofhamburgmn.com>, Jessica Weber <jweber@cityofhamburgmn.com>, Tim Tracy <ttracy@cityofhamburgmn.com>

Jeremy,

I was going to try and find an example in Hamburg or Carver County where two properties abut each other and own the land underneath ROW or an easement. However, I can't find an example, so am going to try and illustrate it.

The first image below is a situation found in some rural communities where (for example) two properties (either owned by different people or the same person) are approached by some government jurisdiction. That jurisdiction wants to put a road between the two properties and maintain it via a ROW or easement agreement, but let the property owners hold ownership of the land (for one reason or another). The below situation would have two properties with legal descriptions that abut each other (meeting the county's requirements for combination).

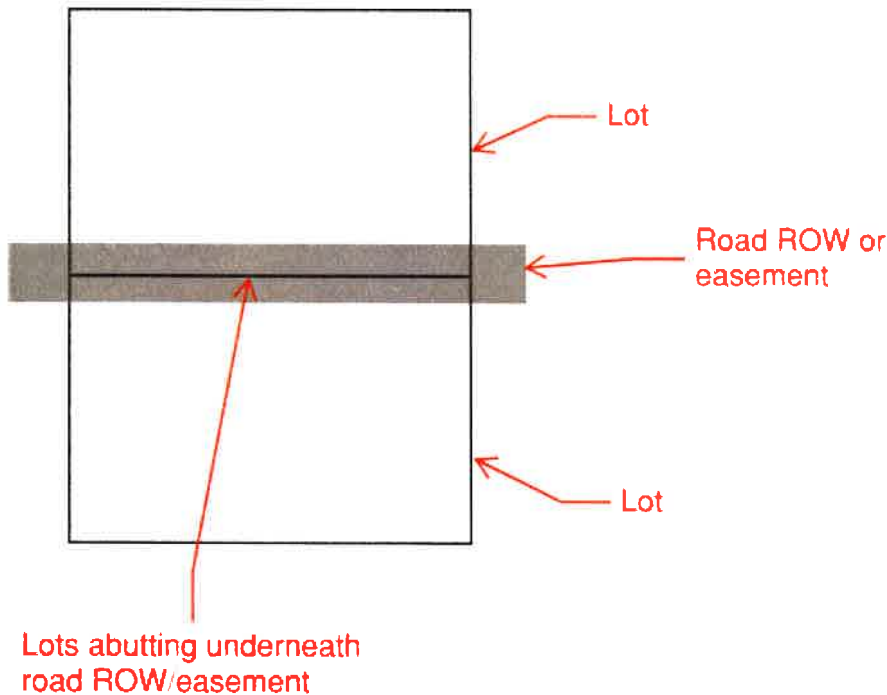

The above image is in contrast to the below image, where a property is subdivided and ROW platted.

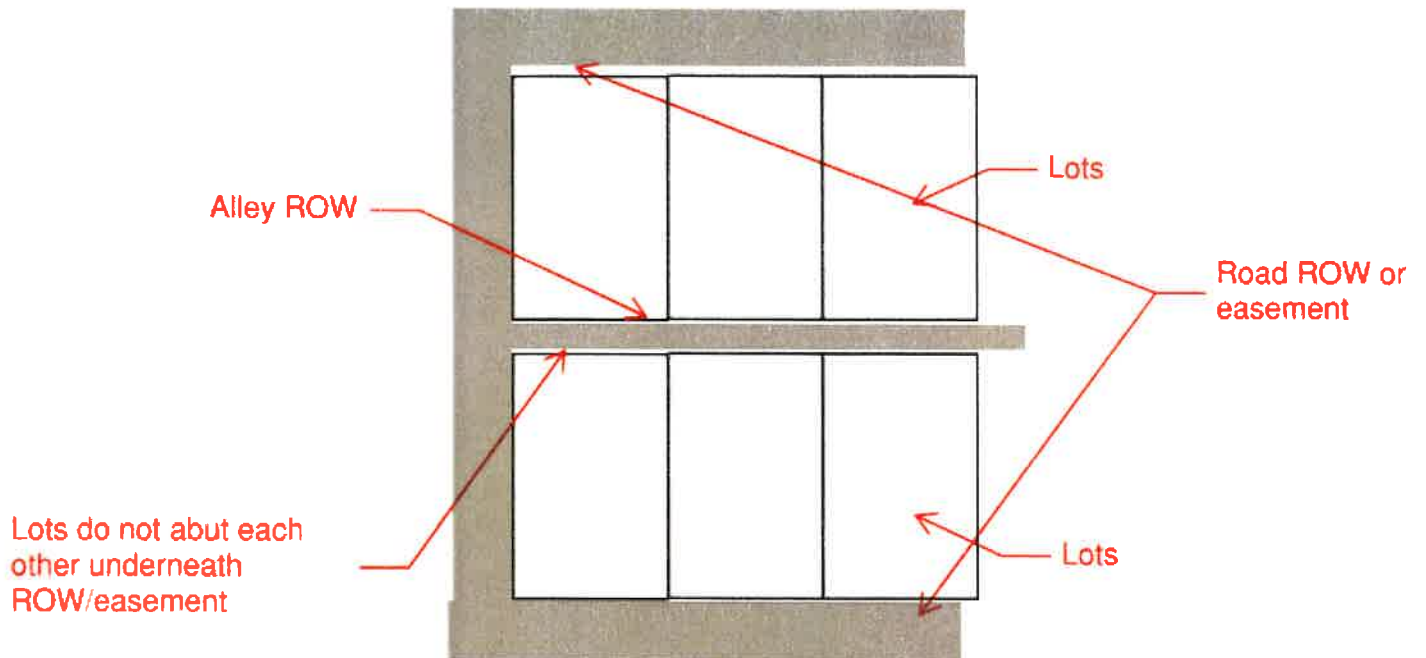

Of course, someone could request and successfully vacate ROW to have lots abut each other.

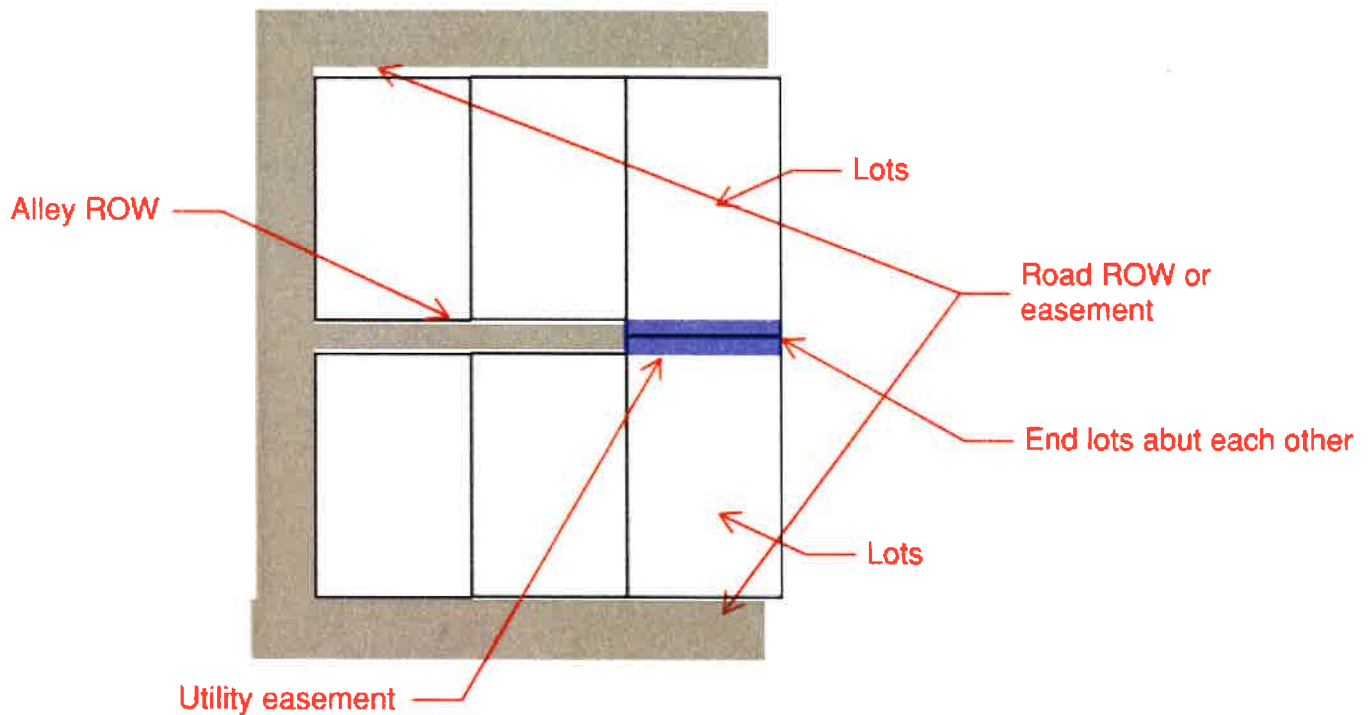

Vacating the end of the alley ROW in the example may result in (i.e.) Public Works asking to retain an easement for water where the alley ROW once was. The county would be allowed to combine the parcels even if an easement for a water main was retained.

To summarize: if the legal description of both properties touch (the lots abut each other), then that is allowed by the county- even if "underneath" ROW. Platted ROW in subdivisions and plats 99% of the time do not have property legal descriptions touching underneath them, but vacating ROW could result in two properties touching where they previously did not.

Does this help? I am happy to talk more over the phone.

## Sewer/Water Utility -

Policy  
or  
Ordinance ?

### Materials

#### General

All trace wire and trace wire products shall be domestically manufactured in the U.S.A.

All trace wire shall have HDPE insulation intended for direct bury, color coated per APWA standard for the specific utility being marked.

#### Trace wire

- **Open Trench** - Trace wire shall be #12 AWG Copper Clad Steel, High Strength with minimum 450 lb. break load, with minimum 30 mil HDPE insulation thickness.
- **Directional Drilling/Boring** - Trace wire shall be #12 AWG Copper Clad Steel, Extra High Strength with minimum 1,150 lb. break load, with minimum 30 mil HDPE insulation thickness.
- **Trace wire – Pipe Bursting/Slip Lining** - Trace wire shall be 7 x 7 Stranded Copper Clad Steel, Extreme Strength with 4,700 lb. break load, with minimum 50 ml HDPE insulation thickness.

#### Connectors

- All mainline trace wires must be interconnected in intersections, at mainline tees and mainline crosses. At tees, the three wires shall be joined using a single 3-way lockable connector. At Crosses, the four wires shall be joined using a 4-way connector. Use of two 3-way connectors with a short jumper wire between them is an acceptable alternative.
- **Direct bury wire connectors** – shall include 3-way lockable connectors and mainline to lateral lug connectors specifically manufactured for use in underground trace wire installation. Connectors shall be dielectric silicon filled to seal out moisture and corrosion, and shall be installed in a manner so as to prevent any uninsulated wire exposure.
- Non locking friction fit, twist on or taped connectors are prohibited.

#### Termination/Access

- All trace wire termination points must utilize an approved trace wire access box (above ground access box or grade level/in-ground access box as applicable), specifically manufactured for this purpose.
- All grade level/in-ground access boxes shall be appropriately identified with “sewer” or “water” cast into the cap and be color coded.
- A minimum of 2 ft. of excess/slack wire is required in all trace wire access boxes after meeting final elevation.
- All trace wire access boxes must include a manually interruptible conductive/connective link between the terminal(s) for the trace wire connection and the terminal for the grounding anode wire connection.
- Grounding anode wire shall be connected to the identified (or bottom) terminal on all access boxes.

# Sewer/Water Utility - Trace Wire Specification

- **Service Laterals on public property** - Trace wire must terminate at an approved grade level/in-ground trace wire access box, located at the edge of the road right-of-way, and out of the roadway.
- **Service Laterals on private property** - Trace wire must terminate at an approved above-ground trace wire access box, affixed to the building exterior directly above where the utility enters the building, at an elevation not greater than 5 vertical feet above finished grade, or terminate at an approved grade level/in-ground trace wire access box, located within 2 linear feet of the building being served by the utility.
- **Hydrants** – Trace wire must terminate at an approved above-ground trace wire access box, properly affixed to the hydrant grade flange. (affixing with tape or plastic ties shall not be acceptable)
- **Long-runs, in excess of 500 linear feet without service laterals or hydrants** - Trace wire access must be provided utilizing an approved grade level/in-ground trace wire access box, located at the edge of the road right-of-way, and out of the roadway. The grade level/in-ground trace wire access box shall be delineated using a minimum 48" polyethylene marker post, color coded per APWA standard for the specific utility being marked.

## Grounding

- Trace wire must be properly grounded at all dead ends/stubs
- Grounding of trace wire shall be achieved by use of a drive-in magnesium grounding anode rod with a minimum of 20ft of #12 red HDPE insulated copper clad steel wire connected to anode (minimum 0.5 lb.) specifically manufactured for this purpose, and buried at the same elevation as the utility.
- When grounding the trace wire at dead ends/stubs, the grounding anode shall be installed in a direction 180 degrees opposite of the trace wire, at the maximum possible distance.
- When grounding the trace wire in areas where the trace wire is continuous and neither the mainline trace wire or the grounding anode wire will be terminated at/above grade, install grounding anode directly beneath and in-line with the trace wire. Do not coil excess wire from grounding anode. In this installation method, the grounding anode wire shall be trimmed to an appropriate length before connecting to trace wire with a mainline to lateral lug connector.
- Where the anode wire will be connected to a trace wire access box, a minimum of 2 ft. of excess/slack wire is required after meeting final elevation.

## Installation

### General

- Trace wire installation shall be performed in such a manner that allows proper access for connection of line tracing equipment, proper locating of wire without loss or deterioration of low frequency (512Hz) signal for distances in excess of 1,000 linear feet, and without distortion of signal caused by multiple wires being installed in close proximity to one another.
- Trace wire systems must be installed as a single continuous wire, except where using approved connectors. No looping or coiling of wire is allowed.



# Sewer/Water Utility - Trace Wire Specification

- Any damage occurring during installation of the trace wire must be immediately repaired by removing the damaged wire, and installing a new section of wire with approved connectors. Taping and/or spray coating shall not be allowed.
- Trace wire shall be installed at the bottom half of the pipe and secured (taped/tied) at 5' intervals.
- Trace wire must be properly grounded as specified.
- Trace wire on all service laterals/stubs must terminate at an approved trace wire access box located directly above the utility, at the edge of the road right-of-way, but out of the roadway. (See Trace wire Termination/Access)
- At all mainline dead-ends, trace wire shall go to ground using an approved connection to a drive-in magnesium grounding anode rod, buried at the same depth as the trace wire. (See Grounding)
- Mainline trace wire shall not be connected to existing conductive pipes. Treat as a mainline dead-end, ground using an approved waterproof connection to a grounding anode buried at the same depth as the trace wire.
- All service lateral trace wires shall be a single wire, connected to the mainline trace wire using a mainline to lateral lug connector, installed without cutting/splicing the mainline trace wire.
- In occurrences where an existing trace wire is encountered on an existing utility that is being extended or tied into, the new trace wire and existing trace wire shall be connected using approved splice connectors, and shall be properly grounded at the splice location as specified.

## Sanitary Sewer System

- A mainline trace wire must be installed, with all service lateral trace wires properly connected to the mainline trace wire, to ensure full tracing/locating capabilities from a single connection point.
- Lay mainline trace wire continuously, by-passing around the outside of manholes/structures on the North or East side.
- Trace wire on all sanitary service laterals must terminate at an approved trace wire access box color coded green and located directly above the service lateral at the edge of road right of way.

## Water System

- A mainline trace wire must be installed, with all service lateral trace wires properly connected to the mainline trace wire, to ensure full tracing/locating capabilities from a single connection point.
- Lay mainline trace wire continuously, by-passing around the outside of valves and fittings on the North or East side.
- Trace wire on all water service laterals must terminate at an approved trace wire access box color coded blue and located directly above the service lateral at the edge of road right of way.
- Above-ground tracer wire access boxes will be installed on all fire hydrants.
- All conductive and non-conductive service lines shall include tracer wire.

# Sewer/Water Utility - Trace Wire Specification

## Storm Sewer System

*This section shall be included at the discretion of the facility owner.*

- If the storm sewer system includes service laterals for connection of private drains and tile lines, it shall be specified the same as a sanitary sewer application.
- Lay mainline trace wire continuously, by-passing around the outside of manholes/structure on the North or East side.

## Prohibited Products and Methods

**The following products and methods shall not be allowed or acceptable**

- Uninsulated trace wire
- Trace wire insulations other than HDPE
- Trace wires not domestically manufactured
- Non locking, friction fit, twist on or taped connectors
- Brass or copper ground rods
- Wire connections utilizing taping or spray-on waterproofing
- Looped wire or continuous wire installations, that has multiple wires laid side-by-side or in close proximity to one another
- Trace wire wrapped around the corresponding utility
- Brass fittings with trace wire connection lugs
- Wire terminations within the roadway, i.e. in valve boxes, cleanouts, manholes, etc.
- Connecting trace wire to existing conductive utilities

## Testing

All new trace wire installations shall be located using typical low frequency (512Hz) line tracing equipment, witnessed by the contractor, engineer and facility owner as applicable, prior to acceptance of ownership.

This verification shall be performed upon completion of rough grading and again prior to final acceptance of the project.

Continuity testing in lieu of actual line tracing shall not be accepted.

# Sewer/Water Utility - Trace Wire Specification

## Products

The following products have been deemed acceptable and appropriate. These products are a guide only to help you choose the correct applications for your tracer wire project.

- Copper clad Steel (CCS) trace wire
  - Open Trench – Copperhead #12 High Strength part # 1230-HS
  - Directional Drilling/Boring - Copperhead Extra High Strength part # 1245\*EHS
  - Pipe Bursting/Slip Lining – Copperhead SoloShot Extreme Strength 7 x 7 Stranded part # PBX-50
- Connectors
  - Copperhead 3-way locking connector part # LSC1230\*
  - DryConn 3- way Direct Bury Lug: Copperhead Part # 3WB-01
- Termination/Access
  - Non-Roadway access boxes applications: Trace wire access boxes Grade level Copperhead adjustable lite duty Part # LD14\*TP
  - Concrete / Driveway access box applications: Trace wire access boxes Grade level Copperhead Part # CD14\*TP 14”
  - Fire hydrant trace wire access box applications: Above ground two terminal with 1” conduit. Copperhead part # T3-75-F (Cobra T3 Test Station, denoting “F” includes mounting flange)
- Grounding
  - Drive in Magnesium Anode: Copperhead Part # ANO-12 (1.5 lb)

## Manufacture product options:

The information provided by Copperhead Industries gives you product options to help you choose the correct wire – termination/access points – connectors and grounding products. Other manufactures provide these products; this information is only a guide.

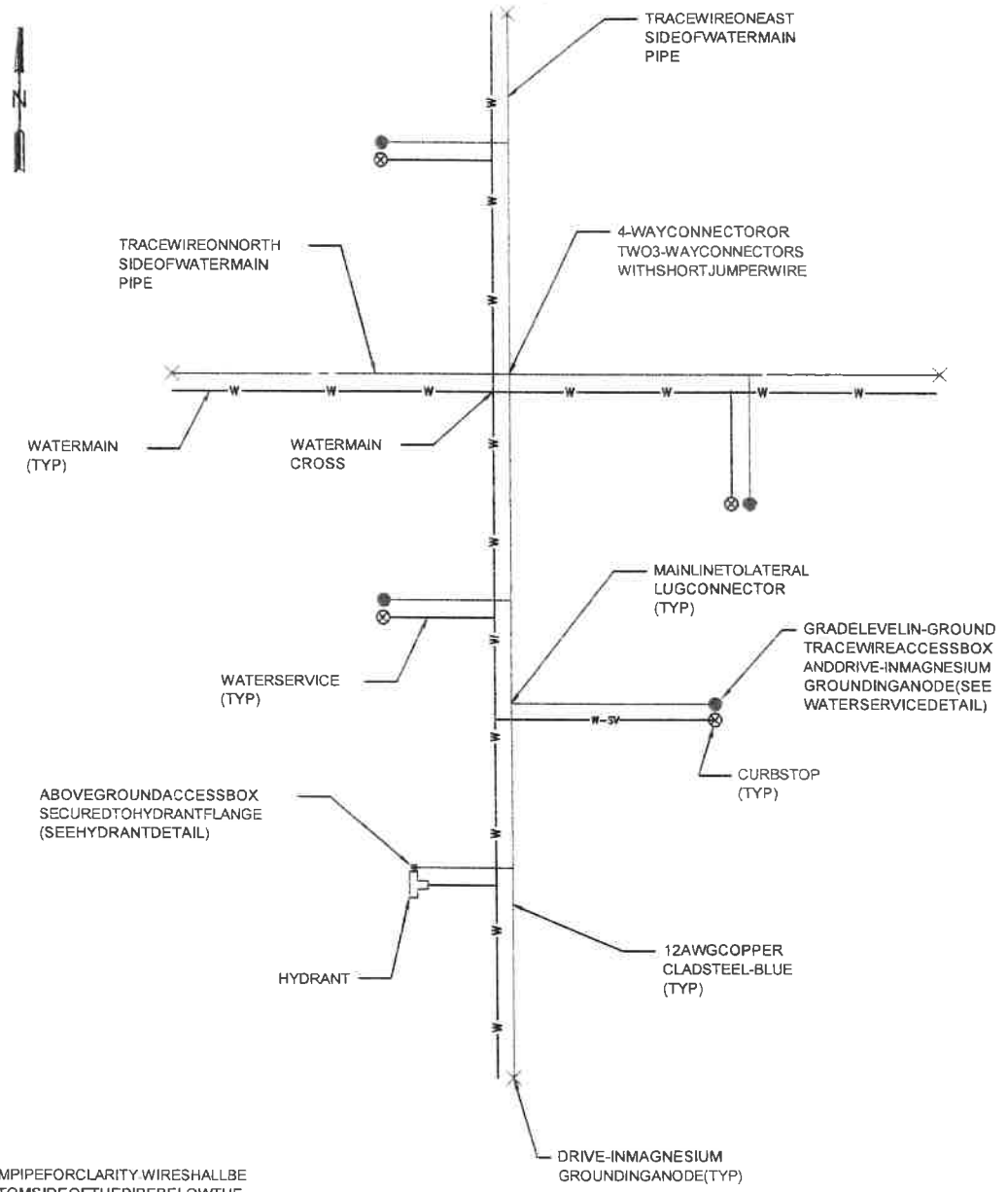

NOTES:  
 1. WIRESHOWNAWAYFROMPIPEFORCLARITY.WIRESHALLBE INSTALLEDONTHEBOTTOMSIDEOF THEPIPEBELOWTHE SPRINGLINE.THEWIRESHALLBEFASTENEDTOTHEPIPE WITHTAPEORPLASTICTIESAT5'INTERVALS.

**TRACE WIRE PLAN (WATER)**

NOSCALE

MINNESOTA RURAL WATER ASSOCIATION  
 STANDARD DETAIL

---

TRACE WIRE  
 SAMPLE WATER PLAN

May 28, 2014

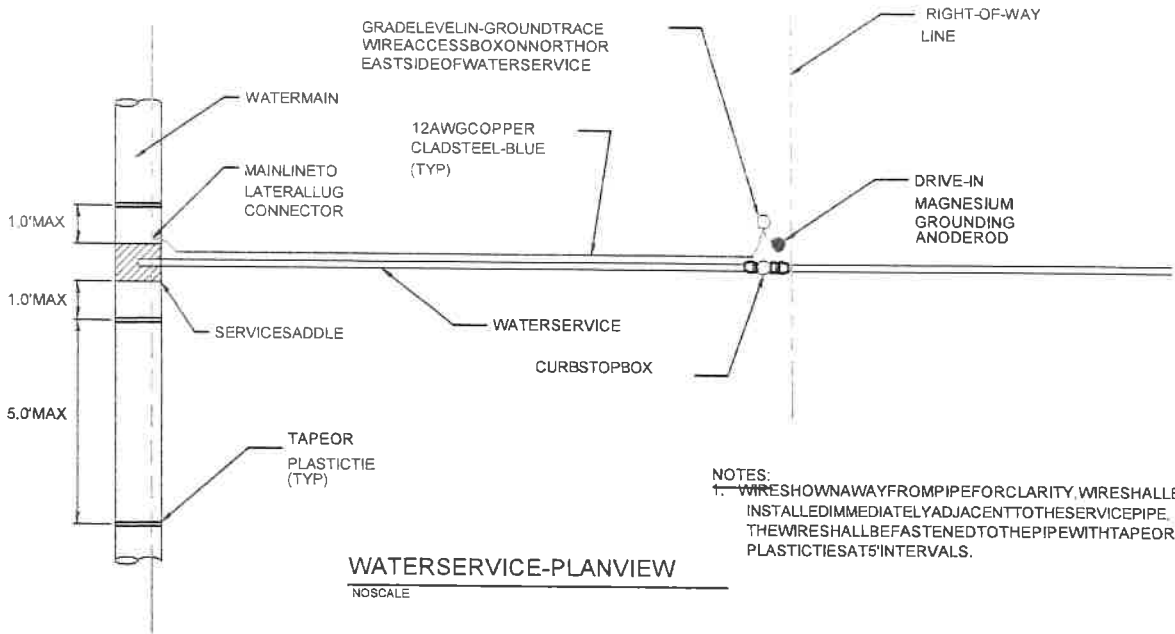

**WATERSERVICE-PLAN VIEW**

NOSCALE

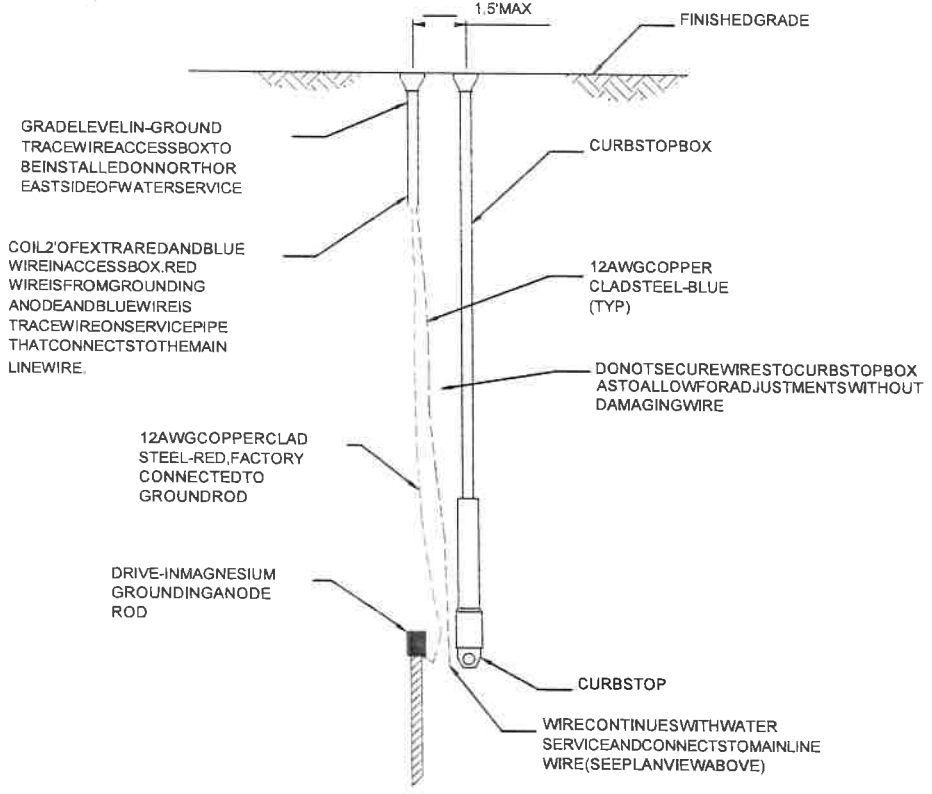

**WATERSERVICE-SECTION VIEW**

NOSCALE



MINNESOTA RURAL WATER ASSOCIATION  
STANDARD DETAIL

TRACE WIRE  
WATER SERVICE DETAIL

May 28, 2014

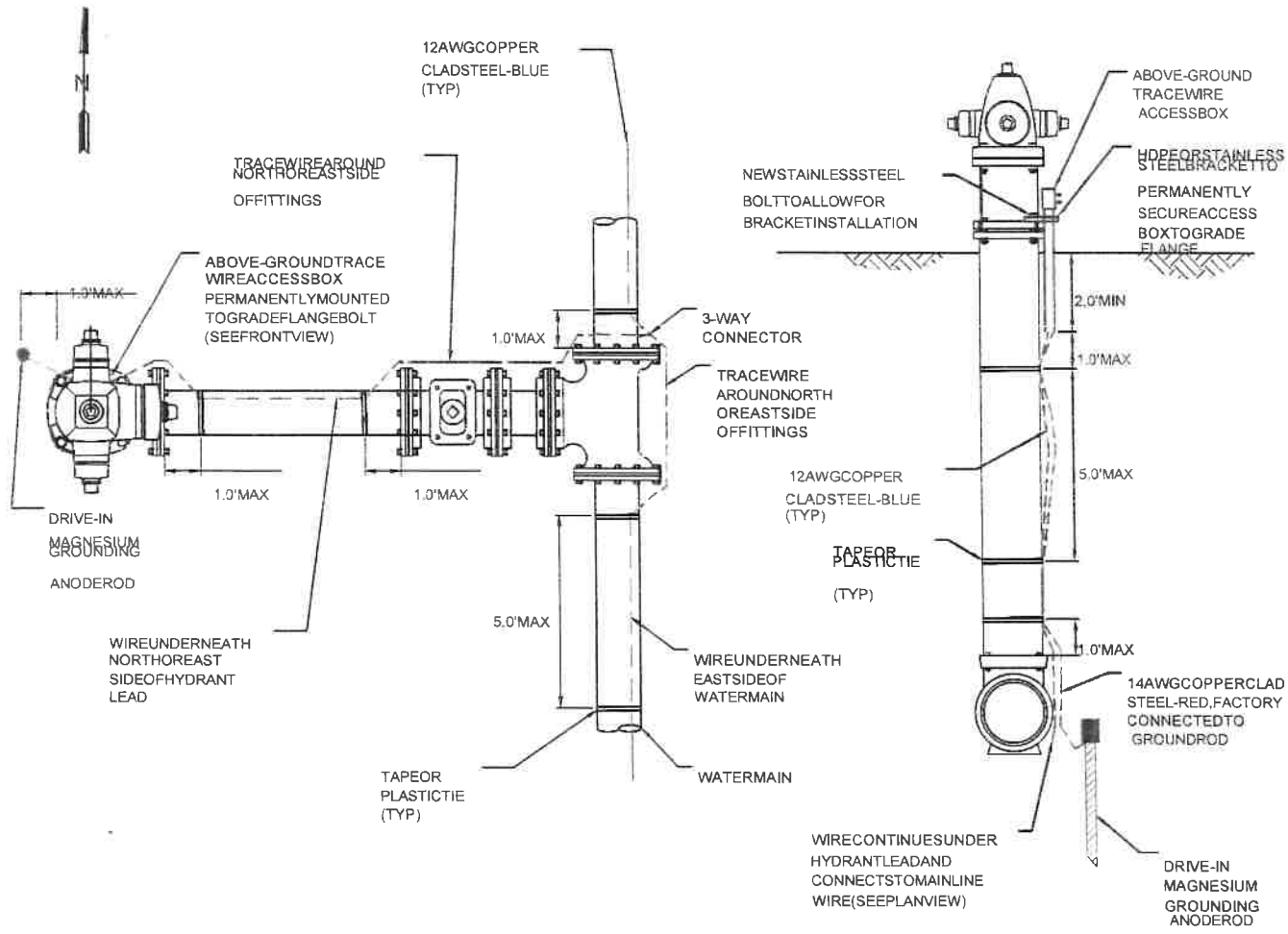

HYDRANT-PLAN VIEW

NOSCALE

HYDRANT-SECTION VIEW

NOSCALE



MINNESOTA RURAL WATER ASSOCIATION  
STANDARD DETAIL

TRACE WIRE  
HYDRANT DETAIL

May 28, 2014

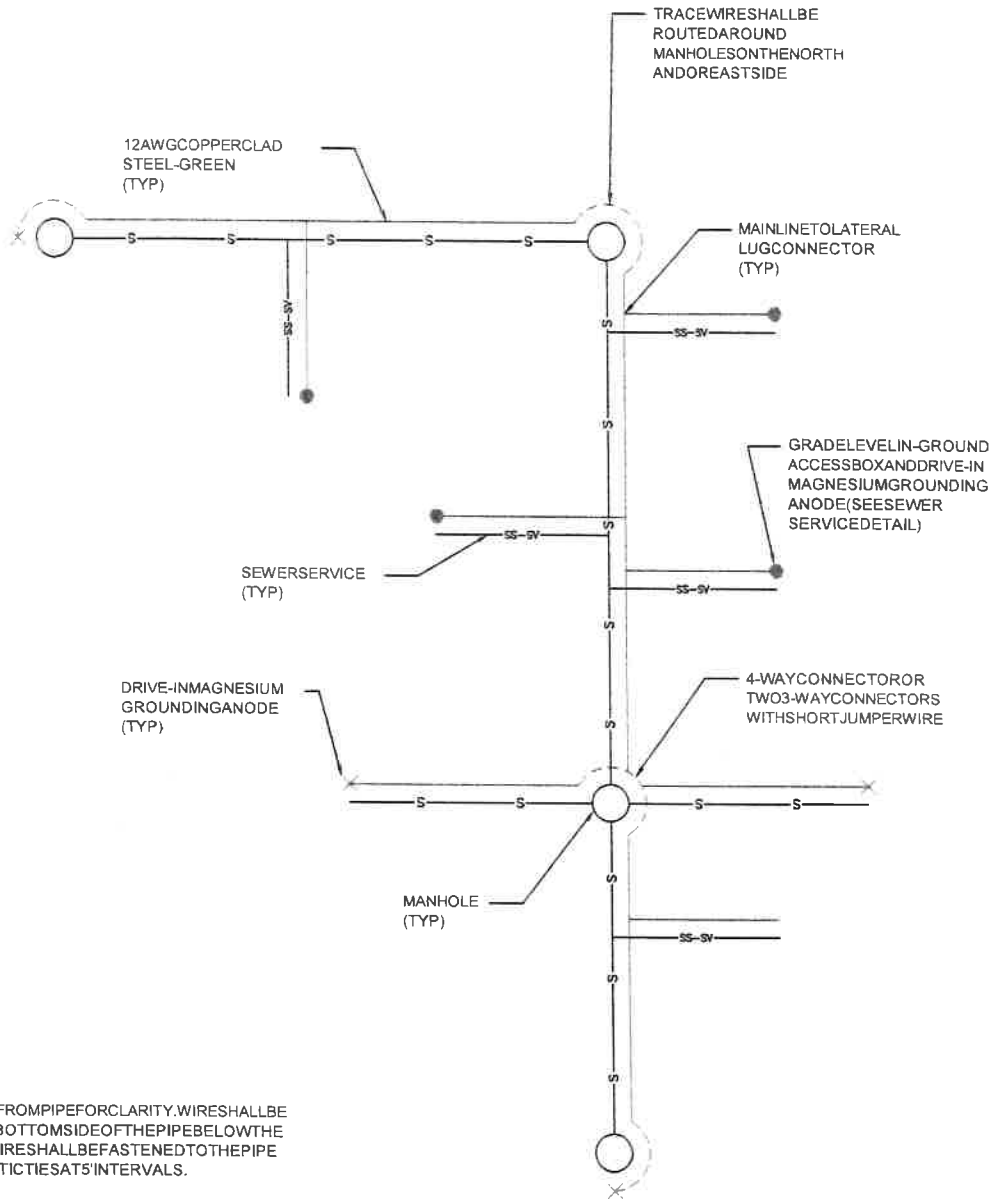

**NOTES:**

1. WIRE SHOWN AWAY FROM PIPE FOR CLARITY. WIRE SHALL BE INSTALLED ON THE BOTTOM SIDE OF THE PIPE BELOW THE SPRING LINE. THE WIRE SHALL BE FASTENED TO THE PIPE WITH TAPE OR PLASTIC TIES AT 5' INTERVALS.

**TRACE WIRE PLAN (SEWER)**

NO SCALE



MINNESOTA RURAL WATER ASSOCIATION  
STANDARD DETAIL

TRACE WIRE  
SAMPLE SEWER PLAN

May 28, 2014

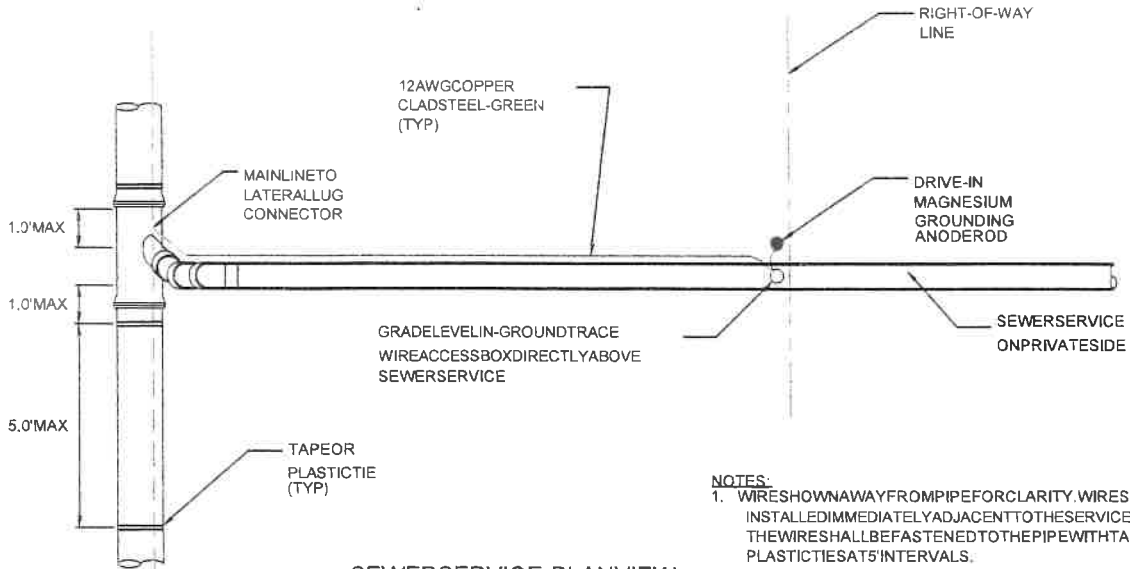

**SEWERSERVICE-PLANVIEW**

NO SCALE

- NOTES:**
1. WIRE SHOWN AWAY FROM PIPE FOR CLARITY. WIRES SHALL BE INSTALLED IMMEDIATELY ADJACENT TO THE SERVICE PIPE. THE WIRES SHALL BE FASTENED TO THE PIPE WITH TAPE OR PLASTIC TIES AT 5' INTERVALS.

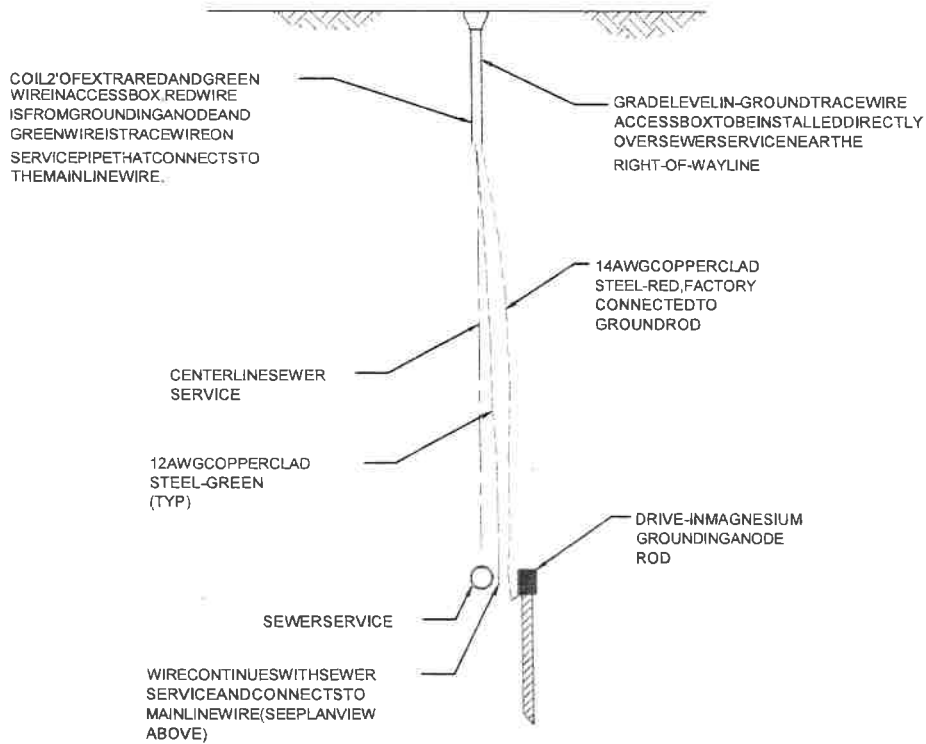

**SEWERSERVICE-SECTIONVIEW**

NO SCALE



MINNESOTA RURAL WATER ASSOCIATION  
STANDARD DETAIL

TRACEWIRE  
SEWERSERVICE DETAIL

May 28, 2014



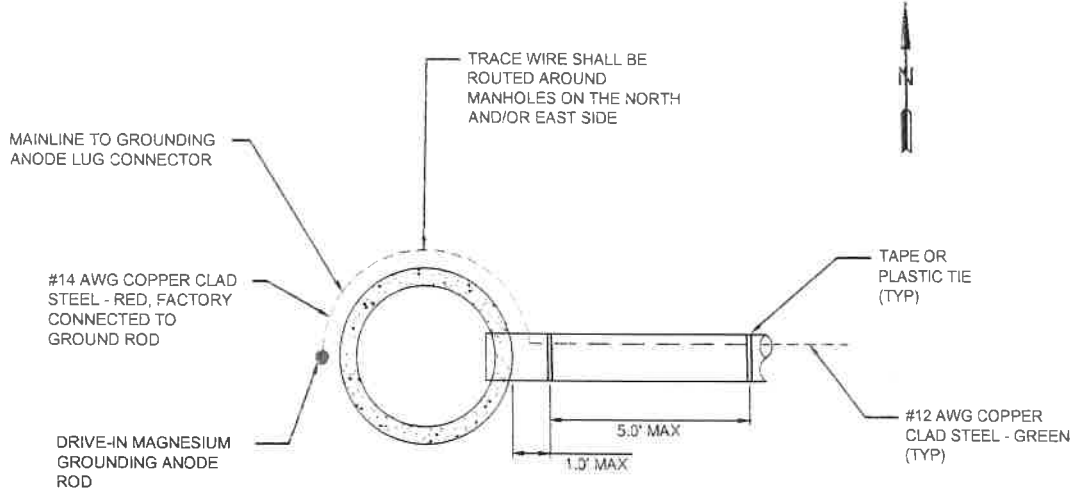

**SEWER MANHOLE - PLAN VIEW**

NO SCALE

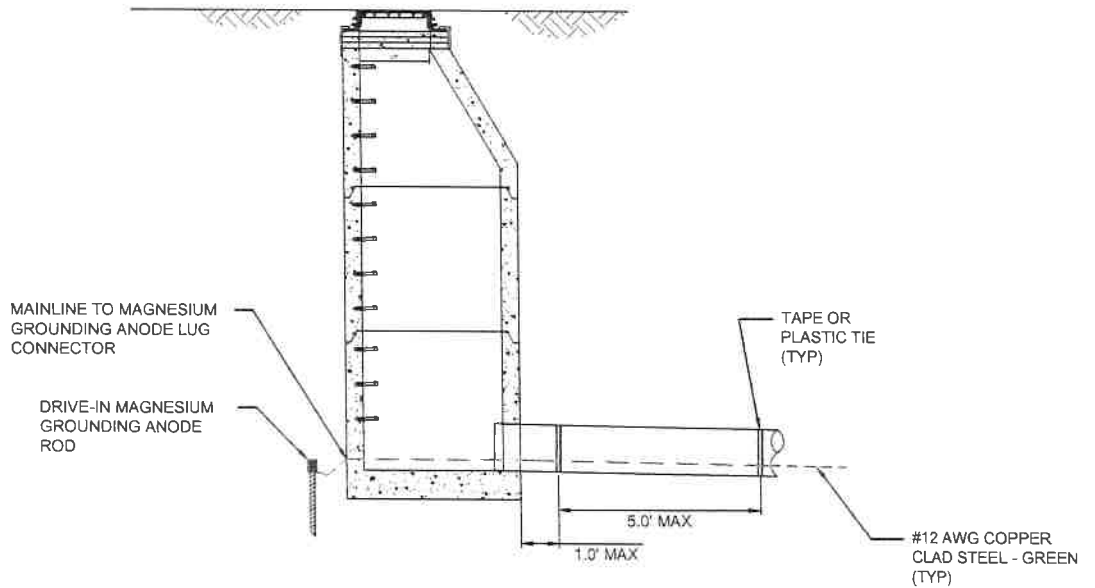

**SEWER MANHOLE - SECTION VIEW**

NO SCALE



MINNESOTA RURAL WATER ASSOCIATION  
STANDARD DETAIL

TRACE WIRE  
SEWER MANHOLE DETAIL

May 28, 2014